

PART B **GENERAL PROVISIONS**

Contents

B1 WASTE	4
1.1 Demolition and Construction	4
1.2 Ongoing Management	6
1.3 Low density Residential Development	7
1.4 All Other Development	8
B2 ECOLOGICALLY SUSTAINABLE DEVELOPMENT	16
2.1 Passive Design and Thermal Safety	18
2.2 Water Conservation	20
2.3 Indoor Air Quality	21
2.4 Renewable Energy and Energy Efficiency	22
2.5 Energy Assessment	25
2.6 Nabers Commitment Agreement	26
B3 LANDSCAPING, BIODIVERSITY AND VEGETATION PRESERVATION	28
3.1 General Provisions	28
3.2 Landscaping	31
3.3 Biodiversity	36
3.4 Protecting Trees on Development Sites	39
3.5 Penalties	39
B4 COASTAL RISK MANAGEMENT	41
B5 WATER MANAGEMENT	41
5.1 Stormwater Management and WSUD	41
5.2 Flood Planning	43
B6 ACCESSIBILITY AND ADAPTABILITY	58
6.1 Accessibility	59
6.2 Adaptable Dwellings	60
6.3 Universal Housing Design	61
6.4 Unjustifiable Hardship	62
B7 TRANSPORT	63
7.1 Streetscape	64
7.2 On-Site Parking	65
7.3 Loading Facilities	76
7.4 Pedestrian/Bicycle Circulation and Safety	77
7.5 Green Travel Plans	78
7.6 Traffic and Transport Management Plans	79
7.7 Car Share	80
7.8 Electric Vehicle Charging Points	81
B8 HERITAGE	83
8.1 Defining Heritage	84
8.2 Demolition & Excavation	86
8.3 Aboriginal Sites	87

8.4 Heritage Conservation Areas	90
8.5 Landscape Conservation Areas	91
8.6 Character and Streetscape	92
8.7 Siting	94
8.8 Scale and Proportion	95
8.9 Architectural style	97
8.10 Materials and colour	98
8.11 Roofs and Chimneys	99
8.12 Verandahs and Balconies	100
8.13 Garages, Parking and Site Access	101
8.14 Garden Elements	102
8.15 Building Facades	103
8.16 Detailing	104
8.17 Fencing and Gates	105
8.18 Landscaping	107
8.19 Solar panels	108
8.20 Commercial Properties	108
B9 SAFETY	111
9.1 Built Form	111
B10 PUBLIC ART	113
10.1 Public Art in the Private Domain	113
B11 DESIGN EXCELLENCE	114
11.1 Design	114
11.2 Context Analysis	115
B12 SUBDIVISION	116
B13 EXCAVATION	118
B14 ADVERTISING AND SIGNAGE	121
14.1 Design and Location	121
14.2 Site Specific Controls	124
14.3 Sign Specific Controls	128
B15 PUBLIC DOMAIN	132
15.1 Improving the Public Domain	132
15.2 Active Street Frontages	134
15.3 Arcades and Through Site Links	137
15.4 Awnings and Colonnades	139
15.5 Reflectivity	140
15.6 Shopfront Security	141
15.7 Minor Encroachments	142
B16 INTER-WAR BUILDINGS	143
B17 SOCIAL IMPACT ASSESSMENT	147
ANNEXURES	148

B1 WASTE

This Part applies to all works requiring a development application (DA) and is to be read in conjunction with the waste minimisation and recycling clause in the *Waverley Local Environmental Plan 2012* alongside Council's relevant policies and guidelines.

General Objectives

- (a) To support the delivery of the targets and outcomes of the adopted Council environmental action plan, relevant waste and resource recovery strategy, *Waste Avoidance and Resource Recovery Act 2001 and Protection of the Environment Operations Act 1997*.
- (b) To reduce the amount of waste generated and maximise resource recovery during the demolition, construction and ongoing management of a property.
- (c) To facilitate safe and efficient waste and recycling collection from all premises.
- (d) To ensure waste management, removal and disposal is in accordance with the relevant State Government Legislation.
- (e) To support innovative and circular solutions for avoiding waste to landfill in the built environment
- (f) Minimise ongoing operational waste management costs to property owners, occupants, and the Council
- (g) Minimise developments' waste management and collection service impacts on occupants and surrounding areas
- (h) Reduce other impacts on occupants and surrounding areas related to waste management such as traffic congestion, truck movements, greenhouse gas emissions, noise from frequent collections.

General Controls

- (a) The *Site Waste & Recycling Management Plan (SWRMP)* is to be submitted in accordance with the *Waverley Development Application Guide*.

1.1 DEMOLITION AND CONSTRUCTION

Objectives

- (a) Avoid creating construction waste wherever possible
- (b) To maximise the re-use of clean excavated material, sandstone, concrete, bricks and timber.
- (c) To minimise the amount of construction waste that is sent to landfill
- (d) To increase efficiency of development and encourage sustainable practices.
- (e) To ensure the safe removal and disposal of hazardous building materials.

Controls

- (a) A construction waste storage area is to be located within the property boundary and is to be identified on the site plans as part of the *SWRMP*.
- (b) Separate construction waste collection bins *or* construction waste storage areas are to be provided giving consideration to slope, drainage, vegetation, access and handling requirements and may include:
 - (i) Landfill waste;
 - (ii) Recyclable waste;

- (iii) Materials to be re-used on-site; and / or
 - (iv) Excavation materials (refer to *Annexure B1-1* for common building materials that can be re-used and recycled).
- (c) Waste that can be recycled or reclaimed is to be identified in the SWRMP, as well as the intended methods for recovery and reclamation.
- (d) All sandstone must be re-used on site or reclaimed through an appropriate contractor.
- (e) Asbestos and other hazardous material is to be managed under the *Protection of the Environment Operations Act 1997*, in accordance with the provisions of Safe Work NSW, and Council's Asbestos Policy.
- (f) Materials that cannot be reused or recycled must be:
 - (i) Disposed of at a State Government approved facility and specified in the SWRMP; and
 - (ii) Disposed of via a contractor that operates in accordance with the Proximity Principle outlined in State Government Legislation.
- (g) Records are to be retained on-site demonstrating lawful disposal of waste.
- (h) Easy vehicular access to waste and recycling material storage areas must be provided and detailed in the SWRMP.
- (i) Construction materials are to be stored away from waste and recycling materials to enable easy access for waste collectors. Skip bins are to be utilised and located in accordance with Council's building waste and hoardings policy.
- (j) All materials are to be stored in way that:
 - (i) Prevents damage from the elements, and reduces odour, health risks and windborne litter; and
 - (ii) Prevents impacts to the environment under State Government Legislation (including stormwater pollution and runoff).

1.2 ONGOING MANAGEMENT

Objectives

- (a) To ensure new developments and changes to existing developments are designed to minimise waste generation and maximise resource recovery.
- (b) To encourage waste storage facilities that are designed to enable the reuse of materials and source separation to facilitate appropriate recycling.
- (c) To ensure waste and recycling systems are easy to use and complement Council's waste and recycling services.
- (d) To promote safe practices for storage, handling and collection of waste and recycling.
- (e) To prevent stormwater pollution that may result from poor waste and recycling storage and management practices.
- (f) To ensure waste storage areas have sufficient volume, are easily accessible, safe, hygienic and are aesthetically incorporated into the design of the development.
- (g) To prevent impacts to the environment that may result from the incorrect use of bins, litter, excess waste and illegal dumping.
- (h) To minimise impacts of waste and waste bins presented on public land for collection on pedestrian and vehicle access, safety and amenity
- (i) To provide flexibility to expand or reconfigure waste separation systems, so that owners and occupants have options to access a range of waste and recycling services

Controls

- (a) Development for the purposes of any of the following must comply with Part B1.3:
 - Dwelling houses;
 - Dual occupancies;
 - Secondary dwellings;
 - Semi-detached dwellings;
 - Attached dwellings;
 - Multi-dwelling housing.
- (b) Development for the purposes of any of the following must comply with Part B1.4:
 - All other residential accommodation not listed in (a) above;
 - Tourist and visitor accommodation;
 - Commercial development; and
 - Any other development not listed in (a).

1.3 LOW DENSITY RESIDENTIAL DEVELOPMENT

This section applies to development for the purposes of Dwelling houses; Dual occupancies; Secondary dwellings; Semi-detached dwellings; and/or Attached dwellings.

1.3.1 General Controls

- (a) Details of ongoing waste management strategy are to be documented within a *Site Waste & Recycling Management Plan (SWRMP)*.
- (b) A waste and recycling storage area for each dwelling must be located on the relevant lot in a position convenient for both users and waste collection personnel.
- (c) Sufficient space must be provided to accommodate the storage of waste and recycling likely to be generated on the premises between collections and any associated equipment.
- (d) Waste and recycling receptacles must be stored at all times within the boundary of the site and screened from the public and commercial domains unless otherwise approved by Council under Section 68 of the *Local Government Act 1993*.
- (e) All waste and recycling must be inside Council approved bins or skips, with lids closed to reduce littering, stormwater pollution, odour and vermin. Waste and recycling not presented in the correct manner will not be collected.
- (f) Council will supply and service 140L and 240L bins.
- (g) Organic waste should be either treated in a composting or worm farming system or collected separately in a Council approved bin or skip (refer to Annexure B1-5).
- (h) Incineration devices are not permitted.

1.3.2 Amenity

- (a) Waste and recycling storage areas must be visually and physically integrated into the design of the development.
- (b) Waste and recycling storage areas must be designed and located to avoid adverse impacts on the amenity of adjoining sites including noise, odour and visual impacts.
- (c) All waste and recycling receptacles must be put out for kerb-side collection no earlier than the previous evening.
- (d) All waste and recycling receptacles must be removed from the kerb-side or laneway as soon as possible on the same day as the collection service.

1.3.3 Ongoing Management

- (a) Ongoing management of the property is to be in accordance with the approved SWRMP to ensure that appropriate waste and recycling services are provided.
- (b) Waste generated by a development must not exceed the maximum permitted generation rates for the building use.

1.4 ALL OTHER DEVELOPMENT

This section applies to development for the purposes of the following: all residential accommodation not affected by *1.3 Low Density Residential Development* above; Tourist and visitor accommodation; Commercial development; and/or any other development.

Please note that:

- Backpacker accommodation is a commercial property use and requires a commercial waste service.
- Boarding houses/time shares/co-living housing, serviced apartments, retirement village, and independent living are residential uses and require a domestic waste service, incurring a Domestic Waste Charge.

1.4.1 Waste Storage Areas

1.4.1.1 GENERAL CONTROLS

- (a) Details of ongoing waste management strategy are to be documented within the SWRMP and reviewed every 5 years (or earlier when needed) to employ updated waste reduction strategies and technologies.
- (b) Sufficient space must be provided to accommodate the storage of waste and recycling likely to be generated on the premises between collections and any associated equipment. Minimum waste and recycling generation rates for various commercial and residential developments are provided in Annexure B1-2.
- (c) Ensure bins can be placed side-by-side and can be easily manoeuvred (no stacking).
- (d) Bin-carting route from the storage area to the collection point is safe and convenient with no steps or steep gradients.
- (e) Waste storage rooms or areas are to be easily accessible by residents and users of the waste system (<30 m from collection point).
- (f) Waste rooms are not to be used for any purpose other than the storage of waste and/or waste infrastructure.
- (g) Where a door or gate opens inwards, no bins are stored within the arc of the swinging door. Where a door or gate opens outwards, the gate does not block the pathway for moving bins out to the collection point.
- (h) Waste and recycling receptacles must be stored at all times within the boundary of the site and concealed from the public and commercial domains unless otherwise approved by Council under Section 68 of the *Local Government Act 1993*.
- (i) All waste and recycling must be inside Council approved bins or skips, with lids closed to reduce littering, stormwater pollution, odour and vermin. Waste and recycling not presented in the correct manner will not be collected.
- (j) Council will supply and service 140L, 240L and 660L bins. The use of 660L bins will only be considered where:
 - (i) The collection point has enough space to present 660L bins without impacting pedestrian access to the footpath and/or driveway of the development;
 - (ii) The collection point is level; and,
 - (iii) Council waste collection vehicle can access the collection point either within the property boundary or at the kerb-side and the collection point meets requirements in Annexure B1-3.

- (k) For developments with 20 dwellings or more, or mixed use developments with more than 200sqm of commercial floor space and a minimum of 10 residential dwellings, advice must be obtained from a waste management consultant to incorporate optimal waste storage and management solutions that recover as much material as possible. Such solutions can be in the form of compactors, chute systems, and/or problem waste storage and collections. Strategies for waste minimisation, and the reduction of waste storage space are to be outlined in the SWRMP.
- (l) Additional space in the bin room is required for waste compactors, chutes, and other infrastructure to easily manoeuvre bins.
- (m) Any volume reducing equipment must be installed in accordance with the manufacturers design specifications and have a space between the unit and the walls to enable easy access for cleaning and maintenance. Compaction rates must not be set higher than 2:1.
- (n) Organic waste should be either treated in a composting or worm farming system or collected separately in a Council approved bin or skip (refer to Annexure B1-5).
- (o) Incineration devices are not permitted.
- (p) Waste and recycling storage rooms must be:
 - (i) Enclosed to prevent noise, odour and visual impacts;
 - (ii) Designed to store the entire fleet of bins plus 0.2m between bins to allow adequate manoeuvrability;
 - (iii) Designed with a 1.8m unobstructed clearance zone between the stored bins and the entrance for access and manoeuvrability;
 - (iv) Designed with suitable door and corridor access to enable bin movement;
 - (v) Constructed of concrete or other approved materials at least 75mm thick;
 - (vi) Finished with a smooth even surface to be easily cleaned;
 - (vii) Coved at the intersection with walls and plinths with a ramp to the doorway where necessary;
 - (viii) Graded and drained to the sewerage system and approved by Sydney Water;
 - (ix) Fitted with a close fitting and self-closing door that can be opened from within the room;
 - (x) Designed with adequate lighting and natural/mechanical ventilation;
 - (xi) Fitted with smoke detectors in accordance with the relevant Australian Standards.
 - (xii) Equipped taps supplying hot and cold water, mixed through a centralised mixing valve with a hose cock and fitted with an aerator to increase water efficiency;
 - (xiii) Designed to include a clear and easy-to-read “NO STOPPING” sign and “DANGER” sign on the external face of waste storage rooms where appropriate;
 - (xiv) Designed to ensure waste-water from the cleaning of the waste storage area and bins, is not to drain into the stormwater system; and
 - (xv) Fitted with childproof compactors or mechanical devices where used in the storage of waste.

1.4.1.2

ADDITIONAL CONTROLS RELATING TO RESIDENTIAL COMPONENTS OF DEVELOPMENT

- (a) A room or caged area with a minimum floor space of 4m² must be provided for the storage of discarded bulky items, awaiting collection. The doorway of this storage area must be at least 1.5m. The following minimum floor space requirements apply:
 - (i) Between 6 and 20 units: 4m²
 - (ii) Between 21 and 40 units: 4m² +1m² for every 10 additional units above 20 units
 - (iii) Between 41 and 100 units: 8m² + 1m² per 20 additional units above 40 units
 - (iv) Over 101 units: 12m² +1m² per 50 additional units above 100 units
- (b) Additional space is required for recycling problem waste such as textiles or electronic waste. The minimum floor space required is 1 m² per 50 units to a maximum 2m². This space should be within or attached to the waste storage area.
- (c) Developments containing more than 3 habitable storeys must:
 - (i) Provide a system for convenient transportation of waste and recyclable material to the communal waste and recycling storage area; Provide a waste and recycling compartment/area on each floor with sufficient capacity to store at least 1 day volume of waste and recycling likely to be generated on that floor; and
 - (ii) Where a chute system is provided, the waste chute garbage material, and an area for bins relating to separated recycling and organic materials must be located together in an allocated communal waste and recycling area on each floor.
- (d) Waste, recycling and organics receptacles must be stored at all times within a building in a designated storage room. Exceptions can be made:
 - (i) Where storage space is available at the side or back of the building, away from public accessibility, and the area can be screened from public and commercial domains; or
 - (ii) Where the storage area at the front of the property is completely enclosed with no risk of public accessibility.
 - (iii) If a waste storage area is outside of the building, the design must complement the primary building and the storage location must be >1m from windows and balconies.

1.4.1.3

ADDITIONAL CONTROLS RELATING TO COMMERCIAL COMPONENTS OF DEVELOPMENT

- (a) All new developments are to provide adequate storage for waste to accommodate future change of use, including increased waste generation rates and grease traps.
- (b) If the commercial use of the property is undecided, minimum waste and recycling generation rates must be applied as per Annexure B1-2.
- (c) Kitchens, office tea rooms, and the like are to be designed with sufficient space for the interim storage of recyclable, organic and general waste in separate receptacles.
- (d) A waste service compartment (waste and recycling area) is to be provided on each floor of the building and have sufficient capacity to store at least 1 day's volume of waste and recycling likely to be generated on that floor.
- (e) A minimum of 2m² floor space for developments under 100m² and 4m² floor space for developments over 100m² must be allocated within the building for the

storage of reusable items such as crates and pallets, and bulk waste such as cardboard or soft plastics.

- (f) Separate space must be allocated for the storage of trade wastewater (within the building where applicable). Trade wastewater must be managed in accordance with a Sydney Water permit and any pre-treatment equipment such as grease traps must meet Australian standards and be properly installed and maintained.
- (g) Liquid waste from grease traps must only be removed by licensed contractors approved by Sydney Water and NSW EPA.
- (h) Waste cooking oil must be stored in sealed containers and stored in a bunded area (an area where leaking oil can't escape). Space must be allocated to store the waste cooking oil and the location must be in an area easily accessible to the oil recycler for servicing.
- (i) For commercial premises that generate 20% or more food waste, or other waste which is considered by Council to have potential amenity impacts, a daily general waste or organic¹ collection is required, unless an alternative is agreed upon with Council.
- (j) For premises that use 660L bins or larger bins, the bins must be lockable and have wheels with working brakes.
- (k) All commercial kitchens in cafes and restaurants or similar must include space for a dishwasher to ensure plates, cutlery and crockery can be washed to reduce reliance on single use items.
- (l) All relevant commercial businesses subject to the requirement of the separation and collection of organic materials, must abide by the relevant State Government mandate per the *Protection of the Environment Operations Act 1997*).
- (m) To minimise collection vehicle movements within the local traffic network, where practical, developments with multiple commercial tenancies should seek to facilitate shared waste disposal, storage and collection.

1.4.1.4 ADDITIONAL CONTROLS RELATING TO ALL MIXED-USE DEVELOPMENT

- (a) In addition to the relevant application of controls from B1.3.3, this section also applies to any mixed use development.
- (b) There must be at least two separate waste and recycling storage rooms or areas, one for commercial waste and recycling, and one for residential waste and recycling. Storage rooms are to be self-contained and have separate keys and locking systems. A separate bulky waste storage room is also to be provided for residents that is inaccessible to commercial premises.
- (c) Mixed-use developments that require the equivalent of 20 x 240L of Mobile Garbage Bins to store their waste and recycling must organise onsite collection or a wheel in/out service.

1.4.2 Access and Collection

1.4.2.1 GENERAL CONTROLS

- (a) Waste and recycling storage areas must be located in a position convenient for both users and waste collection personnel.

¹ Pending the rollout of the NSW Government FOGO mandate for Waverley Council.

- (b) The path for bins between the waste and recycling storage area and the vehicle collection point must be free of steps, narrow gates, vegetation, stepping-stones, loose material, kerbs, and not exceed a grade of 1:14 at any point, unless using an appropriate bin tug device, which must be stored within the waste storage area or adjacent area.
Multi-residential and mixed-use development with more than 20 residential units must accommodate an on-site domestic waste collection service.
- (c) Access roads must comply with the Building Code of Australia, all relevant Australian Standards and *Annexure B1-3*.

1.4.2.2 ADDITIONAL CONTROLS RELATING TO ON SITE WASTE COLLECTION

- (a) On-site waste collection is to be accommodated within a basement or at grade within the building from a dedicated collection point or loading bay that does not impede pedestrian, cycleway, or vehicle movement.
- (b) The on-site waste collection must be designed to allow collection vehicles to enter and exit the property in a forward direction and must have adequate vehicle clearance. Exceptions may be considered where the collection vehicle can back into a driveway safely without impeding pedestrian or vehicle access.
- (c) The on-site waste collection loading point is to comply with the provisions of *Annexure B1-3*.
- (d) The on-site waste collection point may be the same as, or separate to, the waste storage room. Unimpeded and level access is to be provided between the waste collection point and the loading bay.
- (e) The on-site waste collection point is to be of a sufficient size to store all bins to be collected without interruption to the functioning of the development.
- (f) The on-site waste collection point must include a bulky household waste collection point separate (or next to) to the bin collection point..

1.4.2.3 ADDITIONAL CONTROLS RELATING TO WHEEL-IN AND WHEEL-OUT COLLECTION SERVICE

A wheel-in and wheel out service is subject to approval by Council and will only be approved where on-site collection is deemed not feasible for the premises. Council will consider providing wheel-in, wheel-out collection service for residential bins and bulky household waste under the following (but not limited to) circumstances:

- (d) The presentation of the bins at the property would impact on pedestrian access or other safety issues;
- (e) A roller door or similar to access the bin room or a temporary holding area is available on the boundary of the property where the bins would be collected from;
- (f) There is a maximum of 15m between the designated Council waste collection vehicle access point and designated collection point;

- (g) Collection point is accessible from the street, including from a driveway or a designated parking area;
- (h) The waste collection point does not impede traffic or pedestrian flow whilst engaged in the collection of bins/bulky waste;
- (i) Council waste collection vehicle access is available either within the property boundary or street access and meets requirements in Annexure B1-3; and,
- (j) The path for bins between the designated bin storage area and the vehicle collection point must have a flat surface and be free of steps, narrow gates, vegetation, stepping-stones, and loose material.

1.4.3 Amenity

1.4.3.1 GENERAL

- (a) Waste and recycling storage areas must be visually and physically integrated into the design of the development.
- (b) Waste and recycling storage areas must be designed and located to avoid adverse impacts on the amenity of adjoining sites including noise, odour and visual impacts.
- (c) All waste and recycling receptacles must be put out for kerb-side collection no earlier than the previous evening.
- (d) All waste and recycling receptacles must be removed from the kerb-side or laneway as soon as possible on the same day as the collection service.

1.4.4 Management

1.4.4.1 GENERAL CONTROLS

- (a) A current copy of the approved SWRMP is to be available to the building manager and owner's corporation at all times.
- (b) Ongoing management of the property is to be in accordance with the approved SWRMP to ensure that appropriate waste and recycling services are provided.
- (c) Waste generated by a development must not exceed the maximum permitted generation rates for the building use.
- (d) Where a change of use, change of tenant or change in waste management practices will result in a variation to the SWRMP, an application is to be made to Council to revise the approved SWRMP.
- (e) The SWRMP must identify responsibility for:
 - (i) cleaning of waste receptacles and storage areas
 - (ii) for transfer of bins within the property, to the collection point and back to the storage areas.
 - (iii) regular monitoring of bins for contamination and educating residents on how to use the waste and recycling services
 - (iv) inspect, maintain and repair all waste management equipment, such as chutes, bin lifts, compactors and other equipment
 - (v) liaising with the council or the collection contractor on waste management issues and service requests.
- (f) Clear and easy to read signs identifying the different waste receptacles and where in the storage area these should be positioned must be displayed.
- (g) The building manager or owner's corporation is to review every 5 years (or earlier when needed) the methods for waste storage, treatment and collection and implement any relevant changes to reduce waste and increase recycling.

1.4.4.2 ADDITIONAL CONTROLS RELATING TO COMMERCIAL COMPONENTS OF DEVELOPMENT

- (a) All businesses must have written evidence, held on site, of a valid and current contract with a licensed collector of waste and recycling.

- (b) The evidence must include details of each bin size and frequency of collection of each waste stream.
- (c) The management of waste and recycling (including organic collection and/or composting) and any collection system for other waste material, should be clearly outlined in contracts with cleaners, building managers and tenants, along with allocated responsibilities, and included in the SWRMP.

B2 ECOLOGICALLY SUSTAINABLE DEVELOPMENT

This Part applies to all development in the Waverley LGA.

Waverley Council is committed to the highest standards of environmental performance and stewardship of our local area. Council has established long-term environmental targets for Council and Community, covering greenhouse emissions, transport, climate resilience, urban ecology, water management and the sustainable management of waste and materials. Our targets are informed by the best available science and support Ecologically Sustainable Development (ESD) through the following objectives:

- Reducing greenhouse gas emissions to net zero;
- Increasing the use of renewable energy sources;
- Conserving water resources;
- Reducing reliance on mains water supply through the collection and treatment of rainwater and greywater;
- Adapting and responding to climate change to reduce community vulnerability to local climate change impacts and managing climate risks;
- Reducing waste during construction and the ongoing use of the building;
- Increasing recycling of waste and use of recycled products;
- Reducing the environmental impact from building materials through the reduction, re-use and recycling of materials, resources and building components;
- Protecting and improving local biodiversity of sites and surrounding areas.

Residential Development and BASIX

State Environmental Planning Policy (Sustainable Buildings) 2022 applies to residential developments only and aims to ensure homes or apartments are designed to minimise potable water usage and energy usage.

An applicant is required to lodge a BASIX certificate with their development application with Council for:

- New residential buildings;
- Alterations and additions to existing residential buildings where the estimated construction cost of the work is more than \$50,000 and where development approval is required; and
- New swimming pool (or pool and spa) with a capacity of 40,000 litres or more.

More information is available at the following link:
<https://www.planningportal.nsw.gov.au/development-and-assessment/basix>

Mandatory Commercial Building Disclosure

In 2010 the Australian Government implemented a Mandatory Commercial Building Disclosure program under the [Building Energy Efficiency Disclosure Act \(2010\)](#). This program applies to commercial buildings with a net lettable floor area of 1,000sqm or more, and requires owners to disclose energy efficiency information to purchasers and lessees when the space is to be sold, leased or subleased. More information is available from the Australian Government's Department of Industry, Science, Energy and Resources (or equivalent).

Objectives

- (a) To encourage applicants to apply principles and processes that contribute to ecologically sustainable development (ESD) in Waverley.
- (b) To ensure that the design, construction and operation of development minimises adverse impacts on the natural and built environment.
- (c) To improve the quality of life, health and wellbeing of residents and workers.
- (d) To ensure that all development will reduce water consumption and can reduce greenhouse gas emissions to net zero.
- (e) To encourage the replacement of intensive carbon power sources with low carbon and renewable energy.
- (f) To improve indoor air quality.
- (g) To ensure that waste will be reduced and to increase the use of products from recycled sources
- (h) To reduce the environmental impact from building materials through reduction, re-use and recycling of materials, resources and building components
- (i) To reduce urban heat island effect by maintaining and increasing tree canopy, permeable surfaces and deep soil.
- (j) To reduce greenhouse gas emissions from the construction of developments.
- (k) To respond to and prepare for changes in the climate and resource consumption.
- (l) To ensure that development can adapt to climate change.
- (m) To improve local biodiversity.
- (n) To accommodate changing technologies in the design of developments that will provide sustainability outcomes in the built environment for future users.

Controls

- 1) A Statement of Environmental Effects is required to outline how the objectives of ecologically sustainable development will be achieved

2.1 PASSIVE DESIGN AND THERMAL SAFETY

Passive buildings are designed so that windows, walls, and floors are able to collect, store, and distribute solar energy in the form of heat in winter and reject solar heat in the summer. A passively designed house reduces the need for the use of mechanical and electrical (active heating and cooling) systems, saving energy and costs. For more information on passive design refer to: <http://www.yourhome.gov.au/passive-design>

With global warming temperatures predicted to increase a minimum of 1.5 degrees by 2030, Waverley Council is working to ensure that all new homes are built to be thermally safe to live and work in over the lifetime of the building.

Objectives

- (a) To encourage passive design to be integrated into every development from the design stage.
- (b) To encourage passive design through site layout, design and construction to reduce the need for active heating and cooling systems and electric lighting.
- (c) To ensure that local housing responds to regional climate conditions and remains thermally safe for occupants for the lifetime of the building:
 - a. as the climate warms
 - b. during the event of a power failure
- (d) To reduce the energy used in buildings.
- (e) To reduce peak electricity demand of developments.

Controls

- (a) Development is to be designed and constructed to incorporate passive design measures through site design and analysis. Refer to the Design Guidance for methods to achieve this.
- (b) Development must reduce solar heat gain with the following measures:
 - (i) Glazing on buildings must be high-performance low solar gain low-emissivity glass (single or double glazed units).
 - (ii) Skylights must be high-performance low-emissivity glass or double-glazed glass and should be ventilated.
- (c) Development must enable natural ventilation:
 - (i) Windows must be openable excluding windows that are for light ingress or privacy purposes.
 - (ii) Ceiling or wall mounted fans should be in all habitable rooms (main living areas and bedrooms). This should be notated on DA and CC plans.
- (d) Finishes must provide solar absorptance to mitigate the buildup of urban heat:
 - (i) Wall and roof finishes are to have a solar absorptance of < 0.475
 - (ii) Terracotta roofs are to have a solar absorptance of < 0.70
- (e) Development is to incorporate landscaping that provides canopy and vegetation for cooling to provide resilience during hot and dry periods.

Design Guidance

- (f) Development is to consider:
 - (i) Physical characteristics of the site;
 - (ii) Site context, such as adjacent buildings or structures affecting the site, relationship of the site to the street, identification of key features such as views and orientation;
 - (iii) Overshadowing caused by existing buildings;
 - (iv) The orientation of true solar north, and a range of 30 degrees east and 20 degrees west of true north;
 - (v) Trees on, or affecting the site, identifying location, type, size and condition; and
 - (vi) Prevailing seasonal winds, sun and shade characteristics.

- (g) Development is to be orientated to achieve optimum solar access to thermal mass in winter, and shade thermal mass in summer. To achieve this:
 - (i) Shade north and west facing windows from direct summer sun with external horizontal shading devices such as awnings, upper floor balconies, eaves and overhangs; and
 - (ii) Utilise vertical shading devices such as vertical louvres or fins on east and west facing windows that consider the oblique angles of the sun.
 - (iii) The use of trees and shrubs as an additional method of shading a surface or window is encouraged.

- (h) Development must not unduly impact upon the ability of surrounding properties to achieve passive design strategies and solar access.

- (i) Insulation is to be used in external walls and roofs to reduce heat escaping from a building in winter and to maintain a lower internal temperature in summer. Position internal walls and partitions to allow for any prevailing passage of air through the building.

- (j) Development is to utilize operable natural ventilation to evacuate heat from roof or underfloor cavities in summer, and to retain warmth in winter. Design for cross - ventilation or stack-ventilation where possible to minimise the use of mechanical ventilation.

- (k) The use of green roofs or walls to reduce heat absorption and provide thermal mass to a development is strongly encouraged. Refer to *Part B3 Landscaping, Biodiversity and Vegetation Preservation* for additional information.

- (l) The use of trees and vegetation as an additional method of shading a roof, window or surface is strongly encouraged.

2.2 WATER CONSERVATION

Council is strongly committed to conserving water and improving water quality, in order to enhance water security under climate change, protect our waterways and support cooling and greening in Waverley.

Residential developments should implement measures to actively reduce potable water consumption. Residential water conservation measures are required under the State Environmental Planning Policy (Building Sustainable Index: BASIX) 2004.

Objectives

- (a) To encourage sustainable water use practices.
- (b) To reduce the use of potable water.
- (c) To encourage on-site water detention to prevent wastewater and runoff from entering waterways.

Controls

- (a) Rainwater tanks connected to outdoor use and toilets and laundry are strongly encouraged for all residential developments.
- (b) Rain tanks must be fitted with a first-flush device that causes initial run-off rainwater to bypass the tank, and
- (c) Rain tanks must be fitted with a screened rain head designed to prevent leaf litter entering into the water tank, and
- (d) Leaf-shedding grills fitted over gutters and downpipes to increase efficiency of rainwater collection are encouraged, and
- (e) All rainwater tanks plumbed for internal water use must have a filter installed to prevent sediment from entering toilets and washing machines, and
- (f) Pumps attached to the development must be housed in an enclosure that is soundproofed, and
- (g) Rain tanks must have its overflow connected to an existing stormwater drainage system that does not discharge to an adjoining property, or cause a nuisance to adjoining owners
- (h) Rain tanks must have a sign affixed to it stating the water in it is rainwater

Design Guidance

For more information about rainwater tanks and water conservation refer to:

<http://www.yourhome.gov.au/water/rainwater>

2.3 INDOOR AIR QUALITY

National Environment Protection Measures exist to achieve ambient air quality that allows for the adequate protection of human health and well-being. Solid fuel burning is associated with adverse health effects, including respiratory effects in adults.

A systematic review on solid fuel combustion exposure and respiratory health in adults in Europe, USA, Canada, Australia and New Zealand found that reducing solid fuel burning improves air quality and improves respiratory health (Guercio et al., 2022). Similarly, the combustion of natural gas in homes for cooking and space heating purposes is linked to 12% of asthma related cases in Australia (Knibbs et al., 2018). This is a result of chemicals such as nitrogen oxides, carbon monoxide, and sulfur dioxide, as well as particulate matter (PM_{2.5}) and formaldehyde, all of which cause inflammation in airways which can result in asthma symptoms (Musgrave, 2020). Electrifying our homes will reduce these pollutants, improving our indoor and outdoor air quality, with significant health benefits for homes and workplaces.

This DCP chapter looks to promote human health through a reduction in polluting fuels and increased ventilation requirements.

Objectives

- (a) To ensure that ambient air quality levels as specified in the National Environment Protection Measure (Ambient Air Quality) are met for:
 - Carbon monoxide
 - Nitrogen dioxide
 - Ozone
 - Sulfur dioxide
 - Particulate matter (PM₁₀ and PM_{2.5})
- (b) To improve Indoor Air Quality (IAQ) levels in the built environment, specifically for:
 - Nitrogen oxides
 - PM
 - Volatile Organic Compounds (VOCs)
 - Poly Vinyl Chloride (PVC) and
 - Mould

Controls

- (a) All residential development must enable ventilation:
 - (i) Windows must be openable excluding windows that are for light ingress or privacy purposes.
 - (ii) Carpark ventilation required under Building Code of Australia clause F4.11 must also integrate CO monitoring and Variable Speed Drive motors.
- (b) Solid fuel heating and cooking systems are not permitted in any development.
- (c) Gas cooktops, gas ovens or gas internal space heating systems are not permitted in any residential development. Instead, electric systems should be installed and clearly marked on DA plans.

2.4 RENEWABLE ENERGY AND ENERGY EFFICIENCY

Waverley Council has set an ambitious target to reduce community greenhouse emissions to net zero by 2035. In order to meet this reduction target, all new homes are required to have future capacity to be an all-electric building, powered only by renewable energy.

To achieve net zero by 2035, installing natural gas appliances in new developments is not recommended.

Fluorescent and compact fluorescent lamps contain small amounts of mercury, a highly toxic agent which bioaccumulates in the environment. Recycling rates of fluorescent lamps are as low as 2% (Environment Victoria, 2022). For this reason, Waverley Council supports energy efficient alternatives to fluorescent lamps, such as Light Emitting Diodes (LEDs).

Energy efficiency measures for new residential developments are stipulated under the State Environmental Planning Policy (Building Sustainable Index: BASIX) 2004. Commercial energy efficiency measures are stipulated under the National Construction Code Section J.

Objectives

- (a) To enable all development to contribute to net zero greenhouse emissions by 2035.
- (b) To reduce the energy demand of all developments.
- (c) To ensure a building can be 100% powered by renewable energy.
- (d) To encourage the installation and use of renewable energy technologies to reduce greenhouse emissions and peak demand.
- (e) To ensure development takes into consideration neighbouring solar technologies in the design of the building.

ControlsSolar photovoltaic system and battery

- (a) The installation of photovoltaic panels with battery storage is strongly encouraged in all developments.
- (b) Developments proposing to install photovoltaic panels in heritage conservation areas must refer to the Heritage on Solar guidelines on Council's website.

Domestic hot water

- (c) An electric hot water system is strongly encouraged in all developments. Recommended systems include:
 1. Electric heat pump (most efficient)
 2. Solar thermal with electric boost (most efficient)
 3. Electric storage

Where a gas hot water system is proposed, specific inclusions shall be provided so that an electric hot water system can be easily retrofitted in the future. See **Design Guidelines** below for recommended requirements for different building types.

Swimming pool heating

- (d) Recommended swimming pool heating systems include:
- Solar thermal only
 - Solar thermal boosted with electric heat pump
 - Electric heat pump

Gas cooking and space heating

- (d) Gas cooktops, gas ovens and gas space heating systems are not permitted in residential development as outlined in WDCP *Part 2.3 Indoor Air Quality*.

Solar access

- (e) Shading from nearby buildings and canopy trees should maintain solar access to existing photovoltaic solar panels and solar hot water heaters.

Lighting

- (f) Recommended lighting systems include LEDs with controls, such as motion sensors, step-dim controls and daylight sensors.

For more information about renewable energy and energy efficiency refer to:
<http://www.yourhome.gov.au/energy>

Design Guidelines

Class 1 building (Single dwellings) – inclusions for future electric system

If a gas instantaneous or gas storage domestic hot water system is proposed then the following inclusions shall also be provided, so that an electric hot water system can be easily retrofitted in the future:

- A suitable location to place the future electric hot water system, assuming the relevant setback requirements in Section C2 Low Density Residential 2.3.2 are adhered to.
- An additional electrical circuit and breaker for an electric hot water system rated at a minimum of 20 Amps shall be installed at the switchboard.
- Appropriate electrical cabling in situ from the existing electrical switchboard to the future electric hot water system.

Class 2 building (Multi-unit development) – inclusions for future electric system

If multiple gas instantaneous hot water systems or a centralised gas storage hot water system is proposed then the following inclusions shall also be provided, so that an electric hot water system can be easily retrofitted in the future:

Ecologically Sustainable Development **B2**

- i) A suitable location and sufficient space for the future electric hot water system(s) to meet the hot water demand of the residents. This must meet all current Australian Standards for electrical and plumbing installation.
- ii) The existing capacity of the electrical switchboard can meet the electrical demand of the future hot water systems.
- iii) Appropriate electrical cabling is in situ from the existing electrical switchboard to the future electric hot water systems.

2.5 ENERGY ASSESSMENT

Applications which have satisfied section 2.5 *Green Star* are deemed to have fulfilled criteria under 2.5 *Energy Assessment*. An *Energy Assessment Report* is a report that demonstrates that the proposed development's predicted greenhouse gas emissions are 30 percent less than those of a reference building. A reference building is a hypothetical building of the same size, shape, floor area and glazing areas as the proposed development, but whose building fabric and building services characteristics are based on the current National Construction Code Section J deemed to satisfy provisions. Any consent will include a condition to require an Energy Assessment Report prior to the issue of any Construction Certificate.

An *Energy Assessment Report* is not required for residential-only development.

Controls

- (a) A commitment to the provision of an *Energy Assessment Report* must accompany a development application for new mixed use and commercial development with a cost of works of \$3 million or greater. An *Energy Assessment Report* is not required for residential-only development. The commitment is to demonstrate:
 - (i) A proposal which outlines actions that the building will take to achieve greenhouse gas emissions that are 30% less than those of a reference building; and
 - (ii) That an adequately qualified professional has been engaged at the inception of the project to ensure that integrative sustainability measures have been implemented, and that the professional has been contracted to oversee the delivery of the building to these standards.
- (b) An *Energy Assessment Report* is to be submitted prior to the issue of a construction certificate for the development.
- (c) The *Energy Assessment Report* is to include a completed Green Building Council of Australia's Green Star Design & As Built Greenhouse Gas Emissions Calculator available at <http://new.gbca.org.au/green-star/rating-system/design-and-built/> or equivalent modelling tool.
This includes:
 - (i) Modelling of the predicted operational energy demand and greenhouse gas emissions of the proposed development.
 - (ii) Proposed solutions to reduce the predicted operational energy use and greenhouse gas emissions of the site and calculations to show the energy use and greenhouse gas emission reductions attributable to each proposed solution.
 - (iii) Potential solutions include:
 - Full electrification of building.
 - Design of site, buildings and services.
 - Commitment to purchase 100% renewable energy.
 - Use of on-site energy efficient technologies.
 - Use of on-site renewable energy technologies where feasible.

2.6 NABERS COMMITMENT AGREEMENT

Background

NABERS (the National Australian Built Environment Rating System) is a national rating tool which measures the environmental performance of a building, in particular energy and water consumption and waste impact.

A Commitment Agreement is a contract signed by a developer or owner to commit to design, build and commission a building to achieve a specific NABERS energy rating.

Objectives

- To ensure all development will reduce water consumption and can reduce greenhouse gas emissions to net zero
- To encourage the use of rating tools to ensure that the environmental performance of the building is verified at occupancy stage and ensure ongoing improvement over time.

Affects:

- i. office buildings > 1000m2 net lettable area
- ii. retail premises > 5000m2 gross lettable area
- iii. hotels > 100 rooms
- iv. residential aged care
- v. retirement living
- vi. one of the above plus mixed use

Control

- a) Affected buildings are to sign NABERS Commitment Energy and Water Agreements according to the schedule outlined in Table 1.

Table 1: Minimum NABERS Commitment Agreement requirements

Building type	Required Commitment Agreement
Office buildings > 1000 m2 net lettable area	5.5 Star Energy 4 Star Water
Retail premises > 5000m2 gross lettable area	5.5 Star Energy 4 Star Water
Hotels > 100 rooms	5.5 Star Energy 4 Star Water
Residential Aged Care ²	5 Star Energy 4 Star Water

² Residential Aged Care is a form of seniors housing that falls under the Housing SEPP 2021. It includes residential care facilities in which residents receive full time care, otherwise known as nursing homes or aged care homes.

Retirement living ³	5 Star Energy 4 Star Water
One of the above plus mixed use	As listed above

³ Retirement living is a form of seniors housing that falls under the Housing SEPP 2021. It is independent living and consists of apartments or villas for seniors and people living with a disability.

B3 LANDSCAPING, BIODIVERSITY AND VEGETATION PRESERVATION

Trees and vegetation are an integral component of the urban environment. They provide habitat for animals, create a distinctive character for an area, visually soften the built environment and improve the natural environment through improved water infiltration, soil stability and air quality.

This part has been developed in accordance with *State Environmental Planning Policy (Biodiversity and Conservation) 2021 (B&C SEPP)* which outlines additional provisions relating to the protection and preservation of trees and vegetation. The terms ‘**vegetation**’ and ‘**clear**’ have specific meanings under the B&C SEPP. This Part adopts the definitions as outlined in the B&C SEPP.

Clearing that is ancillary to development requiring consent will be assessed as part of the development assessment process and may require further assessment and approval under the *Biodiversity Conservation Act 2016*.

This Part of the DCP regulates the clearing of vegetation that is below the Biodiversity Offset Scheme threshold referred to in the *Biodiversity Conservation Act 2016*, and specifies the species, kinds and size of trees protected from damage or removal in the Waverley local government area and for which Council may issue a Vegetation Clearing Permit.

Pruning of all trees to be carried out to Australia Standards AS 4373 – 2007 Pruning of Amenity Trees. Refer to ‘Prune’ in Definitions & Abbreviations section. Pruning in accordance with this Australian Standard prevails over any Council requirement. For the purposes of Part 2.3 of the B&C SEPP, the following vegetation is declared to be vegetation to which the B&C SEPP applies:

- (i) Any vegetation on Land identified as ‘Biodiversity’ on the Terrestrial Biodiversity Map in WLEP; or
- (ii) Any vegetation on Land identified as ‘Biodiversity Habitat Corridor’ in WDCP2022; or
- (iii) A tree identified on the Waverley Significant Tree Register; or
- (iv) A tree or vegetation that forms part of a Heritage Item or is within a Heritage Conservation Area;
- (v) Any tree that has a height of three metres or more; or
- (vi) Any tree that has a canopy spread of three metres or more.

In addition to this Part of the DCP, the *Waverley Tree Management Policy (WTMP)* and *Waverley Tree Management Guidelines (WTMG)* also outlines requirements for all tree and vegetation related activity. Please refer to the WTMP and WTMG for additional information relating to the protection of trees.

3.1 GENERAL PROVISIONS

Objectives

- (a) To ensure the conservation of trees of ecological, environmental, heritage and aesthetic significance.

- (b) To ensure development does not impact on the health of a tree on the site or adjoining properties or street trees.
- (c) To ensure all works to trees are conducted in accordance with the relevant Australian Standards.
- (d) To increase the level of canopy cover by minimising the loss of vegetation and trees.

3.1.1 Exempt Vegetation

The following species of trees are declared weeds under the Biosecurity Act 2015 as prescribed for the Waverley LGA and can be removed without a permit or development consent. However, Council must be notified a minimum of seven days prior to removing any such trees.

Botanic Name	Common Name
<i>Ailanthus altissima</i>	Tree of Heaven,
<i>Celtis sinensis</i>	Hackberry
<i>Citrus spp</i>	Citrus
<i>Ligustrum sinense</i>	Narrow leaved Privet
<i>Ligustrum lucidum</i>	Broad leaved Privet
<i>Nerium oleander</i>	Oleander
<i>Olea europea var. africana</i>	Wild or African Olive
<i>Salix spp</i>	Willows
<i>Schefflera actinophyll</i>	Umbrella Tree
<i>Strelitzia nicolai</i>	Giant Bird of Paradise
<i>Syagrus romanzoffianum</i>	Cocos Palm
<i>Toxicodendron spp</i>	Rhus Tree

Despite any other provisions in this DCP, clearing of vegetation is exempt from the requirement to obtain a Vegetation Clearing Permit in the following circumstances:

- (i) Pruning of a hedge (hedge being defined as a group of two or more trees whether planted in the ground or otherwise, so as to form a hedge and rise to a height of at least 2.5 metres above existing ground level) by no more than 20 per cent of its height and width in any 12-month period;
- (ii) Pruning of a tree with a maximum height of below 5m.
- (iii) Removal of dead branches, palm fronds or palm fruit;
- (iv) Pruning of branches from electricity wires as required by the *Electricity Supply Act 1995*;
- (v) If Council is satisfied that there is a risk to human life or property, e.g. in response to severe storm damage or sudden branch failure. Evidence of the tree’s condition (e.g. arborist or SES report) must be produced at Council’s request. Replacement native trees must be planted if tree/s are removed;
- (vi) Works carried out by state or federal government departments or authorities under current legislative requirement; or
- (vii) If Council is satisfied that the vegetation is dying or dead and is not required as the habitat of native animals.

3.1.2 Vegetation Clearing Requiring a Permit

A **Vegetation Clearing Permit** is required to clear:

- (i) Native vegetation on land identified as 'Biodiversity' on the Terrestrial Biodiversity Map in WLEP; or
- (ii) Vegetation larger than 500m² on land identified as 'Biodiversity Habitat Corridor' in WDCP; or
- (iii) Any tree that has a height of three (3) metres or more; or
- (iv) Any tree that has a canopy spread of three (3) metres or more.

Note: **Development consent** (via a Development Application) is required for clearing:

- (i) Done in conjunction with development that requires consent under Part 4 of the EP&A Act;
- (ii) Of a tree listed on the Waverley Significant Tree Register;
- (iii) Of any vegetation that forms part of a Heritage Item or is within a Heritage Conservation area (refer to Clause 5.10(2) of WLEP);
- (iv) Of vegetation that is an Aboriginal object or that is located in an Aboriginal place of heritage significance.

Where a development has any potential impact on existing trees an arborist report must be submitted.

Tree Assessment

When an application for consent, or a Vegetation Clearing Permit is made, one of Council's qualified arborists will inspect any tree/s to be cleared and undertake a Visual Tree Assessment (VTA). This is a widely accepted arboricultural assessment based on the current health, structural integrity, useful life expectancy and visible damage of the tree. Additional criteria are also taken into consideration including:

- Landscape significance including consideration of the ecological, cultural and amenity value of trees;
- the effect on the health of the tree from pruning;
- whether the tree shows poor form and shape/vigour typical of the species;
- its location within 3 metres of a residence, main building or other significant structure;
- the occurrence (or lack of) other vegetation nearby and whether appropriate replacement species can be planted;
- whether the tree is the identified cause of structural damage to a building, ancillary structure, water main or sewer and if all alternative options of remedying the damage have been considered.

After assessment, the application will either be:

- a. approved; or approved with conditions
- b. pending; awaiting further information or supporting evidence from the applicant
- c. refused; or refused with conditions.

Any application for a Vegetation Clearing Permit should be accompanied with supporting information/evidence such as documented and photographic history of branch failures, the weather conditions at the time of the branch failure; sewer blockages etc.

Presenting this evidence with the initial application can be helpful as it will provide a more complete history of the tree. If no evidence is presented it may result in the refusal of the application.

Tree Replacement

To maintain urban tree canopy cover, when a Vegetation Clearing Permit is granted to clear vegetation, the applicant may be required to replace the vegetation with an advanced approved species which is to be established on their property and maintained to maturity. Where there is insufficient space for replanting advanced vegetation the applicant may provide offset planting on public land. This may be undertaken by entering into a deed of agreement with Council. Generally, for every tree removed, the replacement of three (3) off-site trees will be required with pot size dependent on the canopy spread of the tree(s) to be removed as assessed by Council. Audit checks of replacement planting will be carried out by Council. Refer to Part 3.2.4.

Arborist and Other Specialist Reports

Supporting evidence for the removal or pruning of a tree/s may require a report from a consulting arborist (AQF Level 5) where there is insufficient evidence to support the removal of a tree as assessed against the above criteria. Council may request the applicant to provide an arborist's report for more complex tree assessments such as an aerial inspection; root mapping or identification; fungal or pest problems; or internal diagnostic assessment.

Further supporting evidence may also be required from a structural engineer or licensed plumber if buildings or underground services are affected. Details of requirements for arborist and other specialist reports are listed in the appendices of the WTMG.

3.1.3 Trees considered to pose an imminent danger

- (a) Except for specified emergency situations, expert advice should always be obtained with respect to hazardous trees to confirm their condition.
- (b) Where a hazardous tree is removed (in an emergency situation) due to obvious instability or hazard (e.g. following a storm), Council's Tree Management must be notified prior to removal. It is recommended that evidence of the tree's condition be retained for a period of at least six (6) months after the event and produced at Council's request if needed. Such evidence might include a:
 - (i) Report by a consulting arborist including photographs; and/or
 - (ii) Written statement from the State Emergency Services, if the Service carried out the emergency work at the owner's request.
- (c) If trees are removed for the above reasons it is a requirement to plant replacement trees of a suitable native species to maintain canopy cover in Waverley. Refer to Part 3.1.4.

3.2 LANDSCAPING

Objectives

- (a) To enhance the amenity and visual setting of the site, streetscape, and surrounding neighbourhood.

- (b) To ensure development contributes to the urban canopy.
- (c) To retain and increase remnant populations of endemic flora and fauna.
- (d) To maximise on site stormwater infiltration and minimise off site stormwater runoff.
- (e) To minimise the adverse impacts of light pollution on local fauna.

3.2.1 General Controls

- (a) A Landscape Plan is required to be submitted in accordance with the *Waverley Development Application Guide* and include:
 - (i) A schedule of the common name and scientific name of species to be planted, the size and number; and
 - (ii) A plan showing the location of the plants in the schedule.
- (b) Existing significant vegetation is to be retained and enhanced.
- (c) The landscaping should maintain and increase vegetation and urban tree canopy in Waverley.
- (d) Species should be retained, selected and placed in order to help achieve the following:
 - (i) Cool buildings in summer;
 - (ii) Intercept glare from hard surfaces;
 - (iii) Channel cooling air currents into the dwelling in summer;
 - (iv) Allow sun into living rooms in cooler months; and
 - (v) Provide windbreaks where desirable.
- (e) Existing natural features including sandstone and rock features are to be retained and incorporated as landscape features on the site in order to maintain the natural character of the landscape. Sandstone walls and finishes fronting the public domain are to match the traditional pattern and colour of sandstone in the area.
- (f) Landscaping is to be designed to minimise non-porous areas and maximise on-site infiltration of stormwater. Paved areas are to be semi-porous or graded to maximise on-site infiltration.
- (g) Landscaping must relate to the building scale and assist integration of the development with the existing street character.
- (h) Landscaping should include native plant species and select and position trees to maximise control of sun and winds.
- (i) All development proposals are to be designed to eliminate the impact upon significant trees on site, street trees and trees on adjoining land including public open space and bushland.
- (j) External illumination fixtures must be directed downwards and away from reflective surfaces, avoid spill into parks, reserves and bushland and avoid short wavelength (blue-violet) light.
- (k) Utilise lightweight soil mixes that are porous, able to drain freely, and suitable for the selected plant species. Seek suitable professional advice regarding appropriate soil depths and types. As a guide, Table 1 provides minimum soil requirements.

Plant Size	Minimum Soil Requirements	
Large Trees (>8m height)	Volume	100 cubic metres
	Depth	800mm
Medium Trees (3 – 8m height)	Volume	60 cubic metres
	Depth	800mm
Small Trees (up to 3m height)	Volume	20 cubic metres
	Depth	800mm
Shrubs (up to 3m height)	Depth	600mm
Ground cover and turf	Depth	300mm

Table 1 Minimum soil requirements

3.2.2 Landscape on Structures

Objectives

- (a) To encourage engaging communal open spaces to be created above basement or podiums, or on roof tops.
- (b) To ensure that adequate provision is made for soil depths, structural provisions to support planting, and drainage and waterproofing requirements.

Controls

- (i) Where set downs are provided, ensure the depth is suitable for paving thickness or the required soil depth for the proposed plants.
- (ii) Minimise visual and physical clutter through the careful design of planter beds and mounds.
- (iii) Innovative design strategies that allow integrated seating to be provided through planter beds at 450mm high are encouraged.
- (iv) Provide raised platforms or mounding to achieve greater soil depth to support planting of larger trees in appropriate areas.
- (v) Demonstrate that adequate drainage and waterproofing is provided for the species and volumes of plants and soil.
- (vi) Provide appropriate methods for capturing, storing and treating run off from landscapes on structures for reuse on the site.
- (vii) Utilise lightweight soil mixes that are porous, able to drain freely, and suitable for the selected plant species.

3.2.3 Green Roofs and Walls

Objectives

- (a) To encourage the use and installation of green roofs and walls to increase building performance, thermal comfort, fauna habitat, localised air temperature and aesthetics of the urban environment.
- (b) To encourage green roofs and walls in commercial and mixed use zones.
- (c) To encourage green roofs and walls to be integrated into existing and new developments.
- (d) To ensure green roofs are non-trafficable areas which do not cause adverse visual or acoustic privacy impacts on neighbouring properties.

Controls

- (a) Council will determine if a green roof will be considered as landscaped area on a site-by-site basis.
- (b) Green roofs are not to be used as recreational areas.
- (c) The selection of plant species must give consideration to sun access, wind, views, overshadowing and other environmental conditions.
- (d) Utilise lightweight soil mixes that are porous, able to drain freely, and suitable for the selected plant species. Seek suitable professional advice regarding appropriate soil depths and types.
- (e) Visual impact:
 - (i) Where a green roof or wall affects views, careful consideration is to be taken to ensure the chosen species of plants will not interrupt or diminish views from adjacent properties.
 - (ii) Green roofs must be contained within the overall building height limit.
 - (iii) Green roofs or walls are not to detract from the heritage significance of a building or heritage conservation area.
- (f) Any access is to be for servicing the green roof only.
- (g) To discourage recreational use of the roof, a balustrade at the perimeter is not permitted.
- (h) The green roof is to have a minimum soil depth of 300mm for ground covers.
- (i) Demonstrate that adequate drainage and waterproofing is provided for the species and volumes of plants and soil.
- (j) Provide appropriate methods for capturing, storing and treating run off from landscapes on structures for reuse on the site.
- (k) Consideration should be given to the strength of a waterproofing membrane through the following method:
 - (i) Flood testing
 - (ii) Electrical field vector mapping (EFVM)
 - (iii) Destructive testing.
- (l) The overall design of the green roof should minimise wind uplift.
- (m) Sub-surface drip irrigators should be used to direct moisture to plant roots.
- (n) Irrigation should be provided from rainwater harvesting, treated grey water or treated black water.

3.2.4 Tree Canopy

Objectives

- (a) To protect and increase tree canopy of the LGA.
- (b) To preserve and enhance landscape character.
- (c) To maintain habitat for native fauna.
- (d) To capture the cooling benefits of canopy.
- (e) To support the *Waverley Community Strategic Plan 2022-2032* minimum 29% LGA canopy and shrub cover target.

Controls

- (a) Development must not result in the loss of tree canopy.
- (b) For Development Applications that involve external works, a Landscape Plan must be submitted showing the locations of tree species, other proposed plants species, any existing trees and vegetation to be maintained and the area of the canopy of the Landscape Plan when planting is mature.
- (c) Where a tree that is **3m or more in height or has 3m or more canopy spread** is proposed for removal under a Development Application, replacement planting of suitable species should be planted on the site that maintain or increase the tree canopy on the site when mature.
- (d) Replacement plantings on site must be of the same or greater canopy size when mature than the canopy proposed to be removed as confirmed by a Landscape Plan and Arborist. Replacement trees planted in accordance with control (c) are to be selected from the list of plantings in Annexure B3-2, and **minimum 45L pot sizes**.
- (e) If there is insufficient planting space on site to accommodate a tree of similar dimensions when mature, the applicant will be asked to contribute to offset planting on public land. Generally, for every tree removed, the replacement of a minimum of three (3) off-site trees will be required in accordance with Council's policy.

3.3 BIODIVERSITY

This Part aims to retain, protect and promote the recovery of remnant native vegetation and native flora and fauna, threatened species, populations, ecological communities and their habitats. The requirements for biodiversity provided for by this Part are to be considered in parallel with the Biodiversity Conservation Act 2016.

Since European Settlement, Waverley has lost over 99% of its original vegetation. Waverley contains 5.9 hectares of remnant bushland, occurring as scattered pockets on cliff edges, in parklands, road reserves and within private property, providing habitat and food for native wildlife. Due to their local significance, these remnants must be protected. These areas also contain the threatened plant species, Sunshine Wattle, which are both protected by state and Commonwealth legislation.

Areas of introduced native and non-native vegetation have also been recognised as providing important habitat for native wildlife. Identified biodiversity habitat corridors link areas of remnant vegetation with each other and with recognised non-remnant habitat areas.

Council acknowledges the intrinsic value of remnant vegetation or bushland, as well as the habitat and other environmental values of revegetated areas and the need to protect them from the degrading influences of surrounding development and other urban pressures.

3.3.1 Terrestrial Biodiversity

The following objectives and controls relate to land identified in the **Terrestrial Biodiversity Maps** located within WLEP as remnant vegetation, or land adjoining remnant vegetation. Definitions are included at the end of this DCP.

Waverley's remnant vegetation includes patches of the Critically Endangered Ecological Community Eastern Suburbs Banksia Scrub (ESBS), and the Endangered plant species Sunshine Wattle, *Acacia terminalis subsp. Eastern Sydney*. Both are protected by the *Commonwealth Environment Protection and Biodiversity Conservation Act 1999*, and in the *NSW Biodiversity Conservation Act 2016*.

Objectives

1. To retain, protect and enhance remnant native vegetation for local wildlife and benefits to the community.
- (b) To protect and promote the recovery of threatened species, populations, and endangered ecological communities.
- (c) To reduce the adverse impacts of light pollution on local fauna.

Controls

- (a) A minimum of 90% of the proposed trees, 90% of the proposed shrubs and 90% of the proposed grasses and groundcovers (not including turfed areas) are to be native plants that are listed in *Annexure B3-1*. Cultivars or hybrids of listed plant

species are not to be counted towards this requirement. Landscape plans must include a planting schedule that lists all plant species proposed, the number of plants of each species proposed, and indicate whether each plant species proposed is listed in *Annexure B3-1*.

- (b) Three strata of vegetation are required to be included in landscape design, e.g. (i) tree or tall shrub canopy, (ii) mid-storey and (ii) groundcover layer.
- (c) All plants identified as priority weeds under the Biosecurity Act 2015, and those plants identified by Council as local environmental weeds on the property at the time of development are to be removed by a suitably qualified person.
- (d) Trees with hollows are to be retained for habitat wherever possible to provide habitat for arboreal fauna. Consideration must be given to the potential risk of damage to public or private property as determined by a suitably qualified arborist.
- (e) Sites that are undeveloped should be protected to encourage regeneration from the seed bank. *Sunshine Wattle* has a persistent soil seed bank which may last for up to 50 years (DECCW, 2007:8).
- (f) Council may require additional supporting information for an application including the following:
 - (ii) Vegetation management/protection plan; and
 - (iii) Flora or fauna impact assessment; and/or
 - (iv) An indication as to whether the proposed development is likely to significantly affect threatened species, populations, ecological communities or their habitat assessed in accordance with the *Biodiversity Conservation Act 2016*.
- (g) External illumination fixtures on land adjoining remnant vegetation must be directed downwards and away from reflective surfaces, avoid spill into parks, reserves and bushland and avoid shorter wavelength (blue-violet) light.
- (h) Remnant vegetation is to be protected. However, the removal of remnant vegetation may be authorized under other legislation including:
 - (i) Trees and vegetation are removed/trimmed in accordance with the *Roads Act 1993*;
 - (ii) The work needs to be carried out by Council, the State Emergency Services, the Rural Fire Service of NSW, or a public authority in response to an emergency;
 - (iii) Works are carried out by State or Federal Government Departments or Authorities under current legislative requirements; or
 - (iv) The tree or vegetation is a recognised noxious weed (*Biosecurity Act 2015*). The applicant must first seek advice from Council and Council must be notified in writing seven (7) days prior to the commencement of removal work.

3.3.2 Habitat Corridors and Recognised Habitat

Wildlife movement allows migration, dispersal, interbreeding and recolonisation of fauna species to occur, improving long-term viability of the species and local populations. Wildlife movement also facilitates plant pollen and seed dispersal, thus enhancing the viability of plant populations. Continuous Habitat Corridors are often preferable, but discontinuous 'stepping stone' corridors still contribute significantly to fauna movement and can be improved through habitat enhancement and plantings of local native species.

This part refers to land identified in the ‘**Biodiversity Habitat Corridor**’ Layer in the DCP, accessible on Council’s mapping website.

Waverley Online Mapping Tool	
https://discover.waverley.nsw.gov.au/	
Map Configuration	Planning
Layer	Biodiversity Habitat Corridor

Definitions are included at the end of this DCP.

Objectives

- (a) To ensure development contributes to the landscape character of the area.
- (b) To enhance planted native vegetation and the ecological functions of habitat corridors.
- (c) To reconstruct habitat in non-vegetated areas of designated wildlife corridors that will as far as possible, represent the combination of plant species and vegetation structure of the original community.
- (d) To reduce the adverse impacts of light pollution on local fauna.

Controls

- (a) A minimum of 50% of the proposed trees, 50% of the proposed shrubs and 50% of the proposed grasses and groundcovers (not including turfed areas) are to be native plants that are listed in *Annexure B3-1*. Cultivars or hybrids of listed plant species are not to be counted towards this requirement. Landscape plans must include a planting schedule that lists all plant species proposed, the number of plants of each species proposed, and indicate whether each plant species proposed is listed in *Annexure B3-1*.
- (b) Three strata of vegetation are required to be included in landscape design (i) tree or tall shrub canopy, (ii) mid-storey and (ii) groundcover layer.
- (c) All plants identified as priority weeds under the *Biosecurity Act 2015*, and those plants identified by Council as local environmental weeds on the property at the time of development are to be removed by a suitably qualified person.
- (d) Trees with hollows will be retained for habitat wherever possible to provide habitat for arboreal fauna. Consideration must be given to the potential risk of damage to public or property as determined by a suitably qualified arborist.
- (e) Council may require additional supporting information for an application including the following:
 - (i) Vegetation management/protection plan; and/or
 - (ii) Flora or fauna impact assessment; and/or
 - (iii) An indication as to whether the proposed development is likely to significantly affect threatened species, populations, ecological communities or their habitat assessed in accordance with the *Biodiversity Conservation Act 2016*.
- (f) External illumination fixtures must be directed downwards and away from reflective surfaces, avoid spill into parks, reserves and bushland and avoid short wavelength (blue-violet) light.

3.4 PROTECTING TREES ON DEVELOPMENT SITES

Damage to trees on development sites is often caused because of a failure to appreciate their vulnerability, particularly the root system which can decline in health over several seasons following detrimental alterations to the soil environment. It is necessary that development takes into consideration trees both on the site and those on adjoining sites including street trees.

Objectives

- (a) To ensure development does not impact on the health of a tree on the site or adjoining properties or street trees in accordance with *Australian Standard – AS 4970 – 2009 - Protection of Trees on Development Sites*.

Controls

- (a) When a proposed development may have an impact on trees on the site, on adjoining properties or public trees within 4 metres of the site, the following information is required at these stages:
1. Pre Development Application.
 - Preliminary Tree Assessment.
 2. Lodgement of Development Application.
 - Arboricultural Impact Assessment (include data if previous preliminary tree assessment submitted);
 - Tree Protection Plan – for trees identified as moderate to high retention; and
 - Root mapping report if construction works will occur in structural root zone (SRZ) or there is major encroachment in the tree protection zone (TPZ) of trees to be retained.
 3. Prior to Construction Certificate.
 - Final Tree Protection Plan (if modifications are required);
 - Tree Protection Certification during works.
 - (iv) Prior to Occupation Certificate.
 - Tree Monitoring Report / Final Tree Protection Certification.
- (b) Details of requirements of the above reports are listed in the Waverley Tree Management Guidelines appendices. Development applications must show all associated building works (including stormwater, hydraulic and sewerage works) located within any tree protection zone.
- (c) Selective pruning or removal of trees that conflict with proposed building works may be approved where redesign of the building work is not possible or will result in inferior building performance. However, Council may require the redesign of a development proposal to retain or lessen the impact on a significant or prominent tree.

3.5 PENALTIES

Any clearing of vegetation carried out without a Vegetation Clearing Permit, not in accordance with a development consent, or that is not exempt will be dealt with in accordance with the relevant legislation. This may result in a Penalty Infringement Notice or legal action through either the Local Court or the Land and Environment Court against all parties involved in any breach of the WLEP, the B&C SEPP, or any conditions of consent.

Where a person is guilty of an offence involving the destruction of, injure or damage to vegetation, the court dealing with the offence may, in addition to or in substitution for any pecuniary penalty imposed or liable to be imposed, direct that person to:

- (a) Repair or remedially prune damaged trees;
- (b) Plant new trees and vegetation and maintain those trees and vegetation to a mature growth/or minimum height of five (5) metres; and
- (c) Provide security for the performance of any obligation imposed under paragraph (a) & (b) above.

Note: *injure a tree means but is not limited to:* poisoning; spilling or washing off toxic chemicals; applying herbicides to a tree or within its Tree Protection Zone; damage to tree roots from stockpiling materials, soil compaction, filling, excavation or altering soil levels within its Tree Protection Zone; wounding to tree trunks or the breaking or tearing of roots or branches; wounding to trunks or branches from fixing objects using nails, wires, staples or similar fastening materials e.g. attaching signs, swings, platforms or cubby houses.

B4 COASTAL RISK MANAGEMENT

Coastal risks include risks from erosion, inundation and geotechnical instability. Erosion refers to the wearing away of the land by the action of natural forces. Coastal or tidal inundation is the flooding of coastal lands by ocean waters, which is generally caused by large waves and elevated water associated with severe storms and the peak of the high tide. Geotechnical risks in the coastal zone refer to coastal cliff or slope instability.

This part refers to land identified in the 'Geotechnical Risk' or 'Coastal Inundation' Layers on Council's mapping website.

Waverley Online Mapping Tool	
https://discover.waverley.nsw.gov.au/	
Map Configuration	Planning
Layer	Geotechnical Hazard
	Coastal Inundation

Any application for new buildings, significant alterations and/or additions to existing buildings and/or new swimming pools on properties identified as affected by 'Coastal Inundation' or 'Geotechnical Risk' are required to submit the following with a development application (refer to the *Waverley Development Application Guide*):

- (a) Coastal Risk Assessment; and/or
- (b) Geotechnical Risk Assessment.

Refer to Council's *Coastal Risk Management Policy 2012* for further information

B5 WATER MANAGEMENT

This Part contains planning controls relating to the management of all aspects of the water cycle in an integrated and consistent manner. The planning controls promote the need for long-term sustainable social, ecological and economic outcomes.

This Part is to be read in conjunction with Council's *Water Management Technical Manual* (Technical Manual) which provides further details on controls outlined in Part 5.1. For more detailed information on flood related risks, refer to the section 5.2 of this DCP and relevant Council flood risk management studies and plans.

This Part applies to all development.

5.1 STORMWATER MANAGEMENT AND WSUD

Objectives

- (a) To promote the implementation of Water Sensitive Urban Design (WSUD).
- (b) To minimise the impacts of development upon the water cycle.
- (c) To encourage sustainable development through the integration of stormwater management systems into the landscape.
- (d) To ensure that development considers flooding, coastal water and groundwater protection, habitat creation and improves visual amenity.
- (e) To integrate water sensitive urban design with landscape and building design.
- (f) To reduce the volume of stormwater run-off.
- (g) To promote increased on-site stormwater retention, detention, and recycling.
- (h) To improve catchment water quality.
- (i) To minimise the impacts of urban development upon water balance and surface and groundwater flow regimes.
- (j) To promote infiltration within the "Infiltration zone" and reduce stormwater run-off (refer to Annexure B in the *Water Management Technical Manual*).
- (k) To encourage the use of soft landscaping and permeable paving as an alternative to impervious surfaces.
- (l) To prevent stormwater from overflowing into basement garages of residences.
- (m) To protect existing natural groundwater flows and downstream properties from seepage.

Controls

- (a) A stormwater management plan is required to be submitted with all development applications (except minor alterations, retrofits and the like).
- (b) WSUD principles are to be integrated into the development through the design of stormwater drainage, on-site detention and landscaping and in the orientation of the development rather than relying on 'end of pipe' treatment devices prior to discharge (refer to Figure 1).
- (c) WSUD measures are to be employed to prevent contamination of stormwater.
- (d) Development is to be sited and built to minimise disturbance of the natural drainage system.
- (e) WSUD elements should be located and configured to maximise the impervious area that is treated.
- (f) On site detention is to be designed, installed and maintained in accordance with the *Water Management Technical Manual*.

- (g) Council consent is required for temporary/permanent dewatering and groundwater extraction and use prepared in accordance with the *Water Management Technical Manual*. The proposal is assessed on merits and where appropriate, referred by Council to the relevant Government department for an access licence.
 - (h) Applications for roof water and stormwater harvesting and reuse and grey water or black water treatment systems will be assessed on merit in accordance with the WM Technical Manual.
 - (i) Methods of disposal of stormwater from the site must be provided using one or a combination of the following:
 - (i) Infiltration;
 - (ii) Gravity connection to Council's stormwater system;
 - (iii) Charged system; and / or
 - (iv) Pump system.
- Note:** A stormwater system must be constructed in accordance with *AS/NZS 3500.3:2021 Plumbing and drainage*
- (j) Depending on the extent of disturbed area, the following plans to manage erosion and sedimentation must be submitted with the development application:
 - (i) For areas of disturbance less than 250m², a marked up plan of proposed works and control measures is required;
 - (ii) For disturbed areas between 250m² and 2,500m², an erosion and sediment control plan is required; and
 - (iii) For disturbed areas greater than 2,500m² soil and water management plan is required.

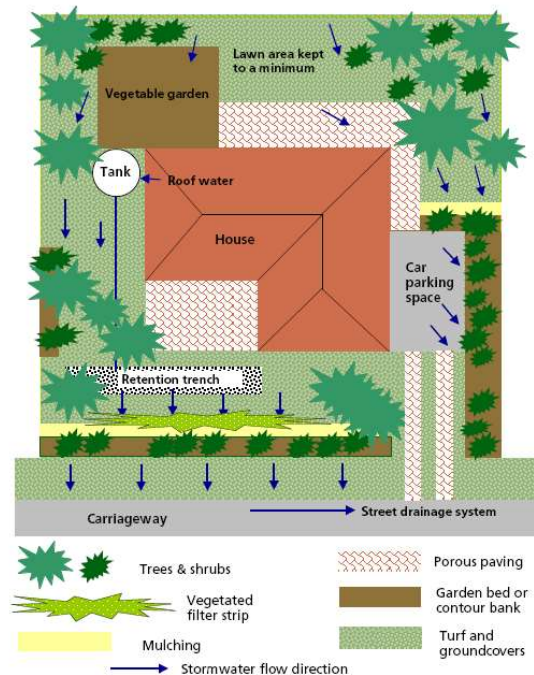

Figure 1 Example of an integrated stormwater strategy for a dwelling

5.2 FLOOD PLANNING

The NSW State Government defines the ‘Floodplain’ as ‘land susceptible to flooding by the PMF (probable maximum flood) event’, and ‘flood’ as natural phenomena where water inundates land that is usually dry, resulting from either (or both) coastal inundation (excluding tsunamis) or catchment flooding. Flooding can be due to water flowing within, out of, or towards a waterway. Water that runs towards a watercourse is known as local overland flow and this type of flooding is the predominant type of flooding that occurs throughout the Waverley Local Government Area.

Other than in Bronte Gully and Tamarama Gully, overland flow flooding in the Waverley LGA does not fit the standard insurers' definition of ‘flood’ in Australia and is sometimes considered as ‘stormwater’ by insurers.

Note: It is recommended that insurers be contacted for a full understanding of policy coverage for individual properties.

Sections 5.2.1-5.2.8 apply to land identified in the ‘Flood Planning Area’ layer on Council’s mapping website ‘Discover Waverley’ and is also provided as a general reference in Annexure B5-3. The three Flood Risk Precincts set out in this DCP cumulatively represent the Flood Planning Area as may be referred to in any relevant environmental planning instrument (such as Waverley LEP 2012 or a State Environmental Planning Policy).

Waverley Online Mapping Tool	
Discover Waverley Mapping Tool	
Map Configuration	Planning
Layer	Flood Planning Area

There are three different levels of potential flood risk associated with the Flood Planning Area - high, medium and low, see below.

Table 1 Flood Risk Precinct Definitions

Flood Risk Precinct	Description	Technical Definition
High	Land within the 1% AEP flood extent with a high hydraulic hazard classification. There is a high potential for damage to property, risk to life or evacuation difficulty. <i>Note: In this precinct there would be a significant risk of flood damages without compliance with flood related building and planning controls.</i>	Land classified as with a “H4- H6” hazard in the 1% AEP event.
Medium	Land below the 1% AEP flood that is not subject to high hydraulic hazard and where they are no significant evacuation difficulties. <i>Note: In this precinct there would still be significant risk of flood damage, but these damages can be minimised by the application of appropriate development controls.</i>	Land classified as with a “H1- H3” hazard in the 1% AEP event.

<p>Low</p>	<p>All other land within the floodplain (i.e. within the extent of the Probable Maximum Flood (PMF), that is not classified as within a High or Medium Flood Risk Precinct.</p> <p>Note: <i>The Low Flood Risk Precinct is where the risk of damage is low for most land uses. The Low Flood Risk Category is the area above the 1% AEP flood.</i></p>	<p>Flood affected land between the PMF and 1% AEP extent.</p>
------------	---	---

Notes:

1. *Delineation of Flood Risk Precincts outlined in Table 1 is provided by Council’s online mapping services “Discover Waverley” based on flood modelling undertaken for Waverley.*
2. *Where sufficient information remains unavailable, but the potential for flood risk issues are evident based on available information, applicants may be required to undertake a site-specific flood assessment. These situations include where:*
 - a) *Council has knowledge that the property has been previously affected by or impacted upon flooding or a local overland flow path;*
 - b) *the property is on the low side of the road and/or the boundary levels are below the level of Council’s kerb;*
 - c) *the property is lower than surrounding properties;*
 - d) *the property is in a natural low point, gully or depression; or*
 - e) *the property is adjacent to or contains a flow path, open channel, watercourse or drainage line.*

The assessment would determine the Flood Risk Precincts in order to apply appropriate controls in addition to any further assessments required by this Development Control Plan.
3. *The mapping of Flood Risk Precincts is undertaken independently of mapping undertaken for Coastal Hazards. Reference should be made to Council’s “Coastal Risk Management Policy” for the mapping and management of land affected by coastal hazards.*
4. *Applicants should obtain a Flood Certificate from Council before preparing a development application. A flood Certificate will confirm key flood related information required for the preparation of a development application for individual properties, where information is available.*

Objectives

- (a) Minimise risk to life and damage to property by controlling development on flood prone land
- (b) Ensure the impacts of the full range of potential floods up to and including the PMF are considered when assessing development having regard to the sensitivity of different land uses to flooding.
- (c) Ensure that development does not have an unacceptable impact on flood behaviour, people's safety, surrounding properties and structures, and the natural environment.
- (d) To provide detailed controls that if satisfied would address the flood risk management considerations required by any relevant environmental planning instrument.

Controls

How to determine what planning controls apply

Refer to land use risk categories in Table 3, and the planning controls matrix in Table 2 to determine which controls are applied.

Application of Controls

Compliance with the prescriptive controls must be demonstrated.

Where the prescriptive controls are not satisfied, applicants must demonstrate, based on site specific assessments, that the performance criteria are clearly satisfied to the satisfaction of Council.

Planning Controls Matrix for Flood Planning

The Planning Controls Matrix (Table 2) identifies the prescriptive flood related development controls that apply to the Flood Risk Precincts and land use categories. Refer to Table 3 for explanations of each land use category.

Table 2 Planning Controls Matrix

Flood Risk	Low Flood Risk							Medium Flood Risk						High Flood Risk							
	Sensitive & Hazardous Development	Subdivision	Residential	Commercial or Industrial	Tourist Related Development	Recreation or Non-urban Uses	Concessional Development	Sensitive & Hazardous Development	Subdivision	Residential	Commercial or Industrial	Tourist Related Development	Recreation or Non-urban Uses	Concessional Development	Sensitive & Hazardous Development	Subdivision	Residential	Commercial or Industrial	Tourist Related Development	Recreation or Non-urban Uses	Concessional Development
Floor Level	3, 6		2, 6	2, 6	2, 6			3, 6		2, 4, 6	2, 4, 6	2, 4, 6	1, 6	5, 6	3, 6		2, 4, 6	2, 4, 6	2, 4	1, 6	5, 6
Building Components	2		1	1	1			2		1	1	1	1	1	2		1	1	1	1	1
Structural Soundness	2				2			2		1	1	2	1	1	2		1	1	2	1	1
Flood Affection								1	1	1	1	1	1	1	1	1	1	1	1	1	1
Car Parking & Driveway Access	1, 3		1, 2	1, 2	1, 2	1, 2	1, 2	1, 3, 4		1, 2, 4	1, 2, 4	1, 2, 4	1, 2, 4	1, 2, 4	1, 3, 4		1, 2, 4	1, 2, 4	1, 2, 4	1, 2, 4	1, 2, 4
Emergency Management	2, 3	1	1	1	1	1	1	2, 3, 4	4	1	1, 3	1, 3	1, 3	1	2, 3, 4, 5	4	1	1, 3, 5	1, 3, 4, 5	1, 3	1
Management & Design		1						2, 3	1	2,	2, 3	2, 3,	2, 3,	2,	2,	1	2,	2, 3	2, 3,	2,	2,
Fencing	1	1	1	1	1	1	1	1	1,	1,	1,	1,	1,	1,	1	1,	1,	1,	1,	1,	1,

Key

No controls	
Subject to significant flood constraints (refer to General Note 1)	
DCP Control Reference no.	1

General Notes:

- 1. Significantly Constrained Land:** This relates to flood affected land where potential development in the nominated land use category is likely to be incompatible with the hazards without substantial mitigation measures. Consequently, the development may be found unacceptable unless mitigation measures can address any potential unacceptable amenity or environmental impacts. Alternatively, this may require a reduction in the otherwise anticipated development intensity for the land.
- 2. Fencing:** Refer to the relevant fencing section of the DCP for planning considerations involving only the erection of a fence for the type of development your application is considered. Any fencing that forms part of a proposed development is subject to the relevant flood effect and structural soundness considerations of the relevant category.
- 3. Freeboard:** Where required the following freeboard heights apply:
 - a. Areas subject to oceanic flooding conditions as depicted in Council’s online mapping service “Discover Waverley” within the ‘Coastal Inundation’ layer: 500mm
 - b. Other areas: 300mm.
- 6. Mixed Use Development:** For mixed-used developments, the planning controls apply to each use to the extent relevant. For example, Floor level and Building Component controls will typically apply to only the ground floor, while the balance of the controls could apply to the overall development.
- 7. Subdivision:** When assessing subdivision the planning controls for the intended end use will be taken into consideration to ensure that any potential development on a new lot would be capable of meeting the controls.

Land Use Categories

Land use is categorised into eight Land Use Risk Categories according to the sensitivity of each type of land use to flooding. The definitions of each land use are primarily based on *the Waverley Local Environmental Plan 2012* and are categorised as follows.

Table 3 Land Use Categories

Category	Land Use
Sensitive and Hazardous Development and Facilities	Centre-based child care centres; community facilities and public administration building which may provide an important contribution to the notification or evacuation of the community during flood events; correctional centres; early education and care facilities; educational establishments; emergency services facilities; group homes; hospitals; hazardous industries; hazardous storage establishments; hospitals; information and education facilities; liquid fuel depots; offensive storage establishments; public utility undertakings (including electricity generating works, sewerage treatment plant, sewerage systems, telecommunication facilities, utility installations and water treatment facilities) which are essential to evacuation during periods of flood or if affected would unreasonably affect the ability of the community to return to normal activities after flood events; respite day care centres; seniors housing; sewerage systems; water supply systems; waste disposal facilities; and waste or resource management facility.
Subdivision	Subdivision of land which involves the creation of new allotments with potential for further development.
Residential	Boarding houses; camping or caravan park site; health consulting rooms; home businesses; home industries; home occupation; backpackers accommodation; bed and breakfast accommodation; hotel or motel accommodation; residential accommodation (excluding seniors housing and residential care facilities); serviced apartments; and other development within residential lots that is not concessional development including but not limited to construction of garages, fencing and/or retaining walls, and swimming pools, and the construction of an outbuilding with a floor area that exceeds 30 m ² , fencing and/or retaining walls.
Commercial or Industrial	Animal boarding or training establishments; commercial premises; and buildings or land used for industry (other than that included as ‘Sensitive and Hazardous Development and Facilities’).
Tourist Related Development	Camp sites or caravan parks (short-term sites only as defined by the <i>Local Government (Manufactured Home Estates, Caravan Parks, Camping Grounds and Moveable Dwellings) Regulation 2021</i>); camping ground, caravan park and eco-tourist facilities.
Recreation or Non-urban Uses	Agriculture; aquaculture; extractive industry; recreation facility (indoor), recreation facility (outdoor); recreation facility (major); recreation areas and minor ancillary structures (e.g. toilet blocks or kiosks); recreation facility (indoor), recreation facility (outdoor); recreation facility (major); and water recreation structure.
Concessional	Residential development that involves: <ol style="list-style-type: none"> the construction of an outbuilding with a floor area of no greater than 30m². an addition to existing premises of not more than 50 m² to the existing ground floor level building footprint, an internal or external alteration to an existing dwelling house, dual occupancy or semi-detached dwelling, which does not change the floor area and/or footprint of the existing dwelling; a change of use which does not increase flood risk having regard to property damage and personal safety; and Subdivision which does not propose the creation of new allotments with potential for further development.

Note

The above land uses are derived from Waverley Local Environmental Plan 2012 and other environmental planning instruments and may not be exhaustive or may change over time. Accordingly, Council may determine the appropriate land use category for the purposes of assessing the flood risk management considerations of this DCP to suit the characteristics of individual development proposals.

5.2.1 Floor Level

Prescriptive Controls

1. All floor levels are to be equal to or greater than the 5% AEP flood level.
2. Habitable floor levels are to be equal to or greater than the 1% AEP flood level plus freeboard.
3. All floor levels are to be equal to or greater than the PMF level unless justified by a site-specific assessment.
4. All non-habitable floor levels shall be no lower than the 1% AEP flood level. Where this is impractical, non-habitable spaces should be flood-proofed to the 1% AEP level.
5. Floor levels shall be equal to or greater than the level of the 1% AEP flood level plus freeboard. Where this is not practical due to compatibility with the height of adjacent buildings, or compatibility with the floor level of existing buildings, or the need for access for persons with disabilities, a lower floor level may be considered. In these circumstances, the floor level shall be as high as practical and when undertaking alterations or additions no lower than the existing floor level.
6. All floor levels (habitable or otherwise) are to be a minimum of 150mm above the adjacent ground level.

Performance Criteria

1. The damage that may be incurred over the expected life of a development should be no greater than that which could be expected by meeting the applicable prescriptive floor level controls.
2. Despite the need to elevate floors, the development must remain acceptable with regard to its appearance and accessibility from the public domain and the amenity of the occupants.

Note:

5.2.2 Building Components

Prescriptive Controls

1. All new structures are to have flood compatible building components below or at the 1% AEP flood level plus freeboard. Refer to Annexure B5-1 for a list of recommended flood compatible building components.
2. All new structures to have flood compatible building components below or at the PMF level.

Performance Criteria

1. All structures are to have flood compatible building materials below the prescribed flood planning floor level.

5.2.3 Structural Soundness

Prescriptive Controls

1. As part of a Flood Impact and Risk Assessment (FIRA), an engineer's report (refer to Annexure B5-2 for details) shall be provided to certify that any new structure can withstand the forces of floodwater, debris & buoyancy up to & including a 1% AEP flood level plus freeboard.

Note: certification to confirm structural soundness up to and including PMF if required to satisfy evacuation criteria (see below).

2. As part of a Flood Impact and Risk Assessment (FIRA), an engineer's report (refer to Annexure B5-2 for details) shall be provided for developments to certify that any new structure can withstand the forces of floodwater, debris & buoyancy up to & including the PMF level.

Performance Criteria

1. All development would be structurally sound when impacted by a 1% AEP flood plus freeboard.
2. Where development relies on sheltering in place to be acceptable it would be structurally sound when impacted by a PMF.

5.2.4 Flood Affection

Prescriptive Controls

1. Unless Council advises it is not required, a Flood Impact and Risk Assessment (FIRA) (refer to Annexure B5-2 for details) shall be provided to certify that the development will not materially increase flood effects elsewhere, having regard to:
 - loss of flood storage;
 - changes in flood levels, flows and velocities caused by alterations to the flood conveyance.

Performance Criteria

1. Development should not increase potential flooding of other properties, or a reduction in the ability of occupants of a property to safely evacuate during a flood.
2. Development should not change the depth or behaviour of flood waters elsewhere in the floodplain in a manner which is likely to materially and adversely impact other property.

5.2.5 Car Parking and Driveway Access

Prescriptive Controls

1. Garages for three (3) or fewer vehicles shall have a minimum finished floor level at the 1% AEP flood level if practical.
2. Basement car parking shall be protected from inundation by the 1% AEP flood plus freeboard.
3. Basement car parking shall be protected from inundation by the 1% AEP flood plus freeboard or the PMF, whichever is higher.
4. Restraints or vehicle barriers to be provided where there is the potential for floating vehicles to leave a site during a 1% AEP flood.

Performance Criteria

1. Measures will be in place to warn people not to drive out of car parking areas where this would be dangerous and provide guidance and facilities to enable pedestrians to safely exit the carpark.
2. All reasonable and practical measures are implemented to reduce the likelihood of motor vehicles being damaged by a flood.
3. All reasonable and practical measures will be in place to manage the potential for vehicles floating and causing damage or becoming debris during a flood.

5.2.6 Emergency Management

Prescriptive Controls

1. The evacuation requirements of the development during flooding shall be considered.
2. Reliable access for pedestrians or vehicles shall be provided from a minimum level equal to the lowest habitable floor level to an area of refuge above the PMF level. Where safe and practical this should involve evacuation to an area outside of the PMF extent, otherwise provide for sheltering in place within a building that would be structurally sound in a PMF.
3. The development shall be consistent with any existing and relevant flood evacuation strategy for the broader area (Waverley Council or State Government).
4. The Applicant shall demonstrate that evacuation of potential development as a consequence of a subdivision proposal can be undertaken in accordance with the Flood Planning controls.
5. The Applicant shall provide a flood emergency response plan that demonstrates how risk to life will be managed during a flood event. For example, a safe evacuation route needs to be clearly identified, or a shelter in-place strategy with reliable access shall be provided to an area of refuge above the PMF level.

Performance Criteria

1. The development should be designed and be able to be managed to ensure that during a flood emergency all occupants are capable of seeking safe refuge.

5.2.7 Management and Design

Prescriptive Controls

1. The Applicant is to demonstrate that potential development as a consequence of a subdivision proposal can be undertaken in accordance with the DCP.
2. The Applicant is to demonstrate that an area is available to store goods above the 1% AEP flood level plus freeboard.
3. No storage of materials below the 1% AEP plus freeboard which may cause pollution or be potentially hazardous during any flood.

Performance Criteria

1. The development should be designed and managed to ensure that during a flood valuable or hazardous goods and materials are capable of being protected.

5.2.8 Fencing

Fencing is not to be constructed in a manner that changes the depth or behaviour of flood waters elsewhere in the floodplain in a manner which is likely to materially and adversely impact other property.

6.2.1 Floor Level

Performance Criteria

5. The cost of damages that may be incurred over the expected life of a development should be no greater than that which could be reasonably expected to be met by the occupants and/or the developer without Government assistance.
6. Despite the need to elevate floors, the development must remain acceptable with regard to its appearance and accessibility from the public domain and the amenity of the occupants.

Prescriptive Controls

1. All floor levels are to be equal to or greater than the 5% AEP flood level.
2. Habitable floor levels are to be equal to or greater than the 1% AEP flood level plus freeboard.
3. All floor levels are to be equal to or greater than the PMF level unless justified by a site-specific assessment.
4. All non-habitable floor levels shall be no lower than the 1% AEP flood level. Where this is impractical, non-habitable spaces should be flood-proofed to the 1% AEP level.
5. Floor levels shall be equal to or greater than the level of the 1% AEP flood level plus freeboard. Where this is not practical due to compatibility with the height of adjacent buildings, or compatibility with the floor level of existing buildings, or the need for access for persons with disabilities, a lower floor level may be considered. In these circumstances, the floor level shall be as high as practical and when undertaking alterations or additions no lower than the existing floor level.

5f.2.2 Building Components

Performance Criteria

7. All structures are to have flood compatible building materials below the prescribed flood planning floor level.

Prescriptive Controls

3. All new structures are to have flood compatible building components below or at the 1% AEP flood level plus freeboard. Refer to Annexure B5-3 for a list of recommended flood compatible building components.
4. All new structures to have flood compatible building components below or at the PMF level.

5.2.3 Structural Soundness

Performance Criteria

8. All development would be structurally sound when impacted by a 1% AEP flood plus freeboard.
9. Where development relies on sheltering in place to be acceptable it would be structurally sound when impacted by a PMF.

Prescriptive Controls

1. As part of Flood Impact Assessment (FIA), an engineer's report (refer to Annexure B5-3 for details) shall be provided for development to certify that any new structure can withstand the forces of floodwater, debris & buoyancy up to & including a 1% AEP flood level plus freeboard. Note: certification to be up to and including PMF if required to satisfy evacuation criteria (see below).
2. As part of Flood Impact Assessment (FIA), an engineer's report (refer to Annexure B5-3 for details) shall be provided for developments to certify that any new structure can withstand the forces of floodwater, debris & buoyancy up to & including the PMF level.

5.2.4 Flood Affectation

Performance Criteria

1. Development does not detrimentally increase the potential flood affectation on other development or properties either individually or in combination with the cumulative impact of development that is likely to occur in the same floodplain.
2. Development should not change the height or behaviour of flood waters elsewhere in the floodplain in a manner which is likely to materially and adversely impact other property. The assessment of these effects must include the potential for similar impacts that would arise as a consequence of other development in the floodplain that has the potential to occur in the future under current zoning and planning controls.

Prescriptive Controls

1. As part of an Flood Impact Assessment (FIA), an engineer's report (refer to Annexure B5-3 for details) shall be provided to certify that the development (including indoor and outdoor features, such as above ground swimming pools and associated pump housing) will not materially increase flood effects elsewhere, having regard to:
 - loss of flood storage;
 - changes in flood levels, flows and velocities caused by alterations to the flood conveyance.

5.2.5 Car Parking and Driveway Access

Performance Criteria

1. Measures will be in place to warn people not to drive out of car parking areas where this would be dangerous and provide guidance and facilities to be able to safely exit the carpark.
2. All reasonable and practical measures are implemented to reduce the likelihood of motor vehicles being damaged by a flood.
3. All reasonable and practical measures will be in place to manage the potential vehicles floating and causing damage or becoming debris during a flood.

Prescriptive Controls

4. The minimum surface level of open car parking spaces or carports shall be no lower than the 5% AEP flood level plus freeboard.
5. Garages for three (3) or fewer vehicles shall have a minimum finished floor level no lower than the 5% AEP flood level plus freeboard.
6. Basement car parking shall be protected from inundation by a 1% AEP flood plus freeboard.

7. The crest of the driveway providing access between the road and basement car- parking shall be a minimum of 1% AEP flood plus freeboard or the PMF, whichever is higher.
8. Restraints or vehicle barriers may be required to prevent floating vehicles leaving a site during a 1% AEP flood. * (Note: A flood depth of more than 200mm will cause serious water damage to a typical vehicle and a depth of 300mm is sufficient to cause a typical vehicle to float.)

**Note: For control no.5. site by site considerations will be assessed based on context and risk.*

5.2.6 Emergency Management

Performance Criteria

9. The development should be designed and be able to be managed to ensure that during a flood emergency all occupants are capable of seeking safe refuge.

Prescriptive Controls

1. The evacuation requirements of the development during flooding shall be considered in the Statement of Environmental Effects.
2. Reliable access for pedestrians or vehicles shall be provided from a minimum level equal to the lowest habitable floor level to an area of refuge above the PMF level. Where safe and practical this should involve evacuation to an area outside of the PMF extent.
3. The development shall be consistent with any relevant flood strategy, Floodplain Risk Management Plan adopted by Council or similar.
4. The Applicant shall demonstrate that evacuation of potential development as a consequence of a subdivision proposal can be undertaken in accordance with the Flood Planning controls.
5. The Applicant shall provide a flood emergency response plan that demonstrates how risk to life will be managed during a flood event. For example, a safe evacuation route needs to be clearly identified, or a shelter in-place strategy with reliable access shall be provided to an area of refuge above the PMF level.

5.2.7 Management and Design

Performance Criteria

1. The development should be designed and managed to ensure that during a flood valuable goods are capable of being protected.

Prescriptive Controls

1. The Applicant is to demonstrate that potential development as a consequence of a subdivision proposal can be undertaken in accordance with the DCP.
2. The Applicant is to demonstrate that an area is available to store goods above the 1% AEP flood level plus freeboard.
3. No storage of materials below the 1% AEP plus freeboard which may cause pollution or be potentially hazardous during any flood.
4. In-ground swimming pools are to have surrounding coping/tiling that is no more than 100 mm above surrounding ground level. All pumping/electricals are to be above the 1% AEP flood level plus freeboard.

5.2.8 Fencing

1. Fencing is to be constructed in a manner that does not obstruct the flow of floodwaters so as to have an adverse impact on flooding.

5.2.9 All Other Areas

- (a) For sites not in a 'flood planning area' habitable floor levels must comply with the drainage requirements of section 5.1 Stormwater Management and WSUD and as specified in the NCC.

B6 ACCESSIBILITY AND ADAPTABILITY

This section applies to all development excluding dwelling houses and other low-density residential development.

Livable Housing Design Guidelines

Livable Housing Australia drives industry best practice through the *Livable Housing Design Guidelines*. A livable home is designed and built to meet the changing needs of occupants across their lifetime. Livable homes include key easy living features that make them easier and safer to use for all occupants including: people with disability, ageing Australians, people with temporary injuries, and families with young children.

Disability Discrimination Act 1992 (DDA 1992)

The *DDA 1992* makes it unlawful to discriminate against a person with a disability in regards to the provision of access to public buildings for the provision of goods and services, accommodation and employment unless this would cause ‘unjustifiable hardship’.

Where an applicant believes that complying with the DCP would cause “unjustifiable hardship,” or detract from the significance of a Heritage Item, an application can be made to be exempted from a particular provision or to provide access for people with disabilities in some other way than provided for in the DCP. It is the responsibility of the applicant to ensure that the development meets the requirements of the *DDA 1992*.

Access to Premises - Australian Standards

Access to Premises - Australian Standards provides the technical specifications for access design requirements in the built environment. The Australian Standards clarify the accessibility requirements for premises as implied under the *DDA 1992* and are incorporated within the National Construction Code (NCC).

6.1 ACCESSIBILITY

Objectives

- (a) To ensure that buildings and public spaces provide for equitable access for all, including people with a disability, ageing people with mobility difficulties, parents with prams, and other people with temporary disabilities.
- (b) To provide an accessible, continuous path of travel to all developments.
- (c) To provide equitable access within all developments.
- (d) To ensure major alterations and additions to existing buildings provides upgraded levels of access and facilities for all people.
- (e) To establish accessible dwelling standards for easy modification to cater for occupants with a disability or impairment.
- (f) To ensure that the siting, design and construction of premises available to the public are to ensure an appropriate level of accessibility, so that all people can enter and use the premises.

Controls

All Development

- (a) Access is to meet the requirements of the *DDA 1992*, the relevant Australian Standards and the NCC
- (b) Accessible parking for people with a disability must be provided in accordance with the NCC and *AS/NZS 2890.1: 2004 Parking Facilities – Off Street Parking*, *AS2890.6:2009 Off Street Parking for People with Disabilities* and *AS 1428: Set 2003* including *AS 1428.1:2009 Design for Access and Mobility*.
- (c) An Access Management Plan for alterations and additions to existing buildings only, may be required as a means of helping to provide services or facilities to people who would be unable to gain access to the premises.

Commercial Development

- (a) The main entrance should provide direct, level access from the street and from any parking area.
- (b) A lift must be provided at ground floor to upper floors in developments with three or more storeys and where aggregate floor area above the ground floor is 400m² or greater.

6.2 ADAPTABLE DWELLINGS

This section is to be read in conjunction with *Australian Standard AS 4299-1995 Adaptable Housing*.

Objectives

- (a) To ensure adequate adaptable housing is provided for within new residential development to accommodate occupants' changing needs over time.
- (b) To ensure adaptable dwellings are included within residential development in accordance with the relevant Australian Standards.

Controls

- (a) Plans identifying adaptable housing are to be submitted in accordance with the *Waverley Development Application Guide*.
- (b) Adaptable dwellings are to be allocated to all dwelling typologies to accommodate various household sizes.
- (c) In developments with 10 or more dwellings, 20% of dwellings (rounded to the nearest whole number) shall comply with the provisions of an adaptable unit as specified in accordance with the *Australian Standard AS 4299-1995 Adaptable Housing*.
- (d) One accessible car parking space is to be provided for every adaptable residential unit and be a part lot in the strata plan.

6.3 UNIVERSAL HOUSING DESIGN

A dwelling of universal design incorporates elements that are ‘designed in’ from the beginning, thus not requiring subsequent modification or adaptation through the lifecycle of occupants.

This section is to be read in conjunction with the *Livable Housing Design Guidelines* produced by Livable Housing Australia.

Objectives

- (a) To increase the supply of universal housing.
- (b) To ensure a suitable proportion of dwellings include universal design features to accommodate the changing needs of occupants over their lifetimes.
- (c) To promote sustainable development by extending the usability of a dwelling to meet ‘whole of life’ needs of the community. To ensure that residential accommodation includes universal design features as best practice.

Controls

- (a) All dwellings in any new medium or high density residential accommodation are to incorporate the universal design features as outlined below (modelled on the *Livable Housing Design Guidelines Silver Level*):
 - (i) A safe and continuous and step free path of travel from the street entrance and/or parking area to a dwelling entrance that is level;
 - (ii) At least one level entrance into the dwelling;
 - (iii) Internal doors and corridor widths that facilitate comfortable and unimpeded movement between spaces;
 - (iv) A toilet on the ground (or entry) level that provides easy access;
 - (v) A bathroom that contains a hobless (step-free) shower recess;
 - (vi) Reinforced walls around the toilet, shower and bath to support the safe installation of grab rails at a later date;
 - (vii) A continuous handrail on one side of any stairway where there is a rise of more than one metre; and
 - (viii) Stairways are designed to reduce the likelihood of injury and also enable future adaptation.
- (b) All universally designed dwellings must be clearly identified on the submitted DA plans. The incorporation of Gold and Platinum Level design features is strongly supported.

6.4 UNJUSTIFIABLE HARDSHIP

It is the responsibility of the applicant to ensure that the development meets the intent of the *DDA 1992*, and the requirements of the Premises Standards and this DCP. However, it is recognised under the *DDA 1992* that in some circumstances the provision of access may cause unjustifiable hardship by being unreasonable, impractical or uneconomical.

Where a developer believes that compliance with the provisions of this DCP and intent of the *DDA 1992* would cause unjustifiable hardship, an application can be made to Council to be exempted from a particular provision, or to provide access in some other way than that specified in this DCP. The information that must be supplied by the applicant is set out in detail under the Controls section of this Part.

In accordance with the *DDA 1992*, Council's assessment of an application for exemption will consider the extent to which people will benefit or be detrimentally affected by non-compliance with this DCP, the cost of compliance and the ability of the developer to meet the cost. Each claim will be considered by Council on its merits as there is no general formula that can be applied to guide what might be considered to be Unjustifiable Hardship.

It must be emphasised that there is always a requirement to provide whatever access is possible up to the point of unjustifiable hardship.

Objectives

- (a) To have public buildings accessible to all people, consistent with requirements under the *DDA 1992* and the NCC.

Controls

- (a) Claims of unjustifiable hardship will be considered on a case by case basis and on the merit of the case put forward by the applicant.
- (b) Unjustifiable hardship is not supported in new developments.
- (c) An application of unjustifiable hardship must be accompanied by a statement that includes the following information:
 - (i) The nature of the benefit or detriment likely to occur or be suffered by any persons in relation to the proposed development;
 - (ii) Two independent quotes from tradespeople or suppliers for the cost of works to meet the principles of the *DDA 1992*;
 - (iii) The space required to carry out works and the effect this may have upon the viability of the proposed work;
 - (iv) The impact on the heritage significance of the premises or conservation area (where applicable) and details of the work required to provide access;
 - (v) Typographical, technical, operational and safety issues;
 - (vi) Details of investigations into different ways in which the space could be configured or used so as to comply with the applicable access requirements; and
 - (vii) Details of investigations into design alterations so that future works to improve access are not compromised.

B7 TRANSPORT

Car parking is one of the most critical planning and transport issues in Waverley. Wherever possible, Council strongly encourages the use of alternative modes of transport such as walking, cycling and public transport and continues to work towards providing better transport connections to the area.

The provision of private (on-site) and public (on-street) parking must be managed in an equitable and environmentally sensitive manner that benefits the community as well as the individual. Where objectives may conflict, Council has a duty to consider broader community benefits in the provision of parking.

Waverley's People, Movement and Places

This Part has been prepared in the context of the Waverley Transport Plan 2017 '*Waverley's People, Movement and Places*.' The aim of *Waverley's People, Movement and Places* is to:

- Create a transit hierarchy for movement in the LGA that prioritises pedestrians and active transport, followed by public transport, service vehicles, shared mobility and private motor vehicles;
- Identify signature projects to invest in; and
- Identify short, medium, long term actions that Council can undertake.

Objectives

- (a) To prioritise trips taken by pedestrians, bicycles and other forms of active transport, followed by public transport, and private vehicles.
- (b) To ensure that new development promotes active and public modes of transport through car share facilities, end of trip facilities, and effective links to public transport.
- (c) To encourage reduced rates of car parking where adequate modes of public or active transport are available.
- (d) To ensure that parking and access do not dominate or adversely impact upon the character of the streetscape, landscape and the development.
- (e) To prioritise and maintain pedestrian amenity and safety.
- (f) To ensure on-street parking supply is protected by minimising impacts of additional vehicular kerb crossings.
- (g) To encourage on site car parking that considers flexibility in the design to allow easy transition to alternate uses in the future.
- (h) To discourage podium or above ground car parking.
- (i) To prevent on street car parking being utilised by occupants with allocated car parking bays.
- (j) To provide convenient and accessible parking that is appropriately designed and located.
- (k) To achieve a high standard of urban design and contribute to the amenity of streetscapes and landscapes.

7.1 STREETScape

Objective

- (a) To ensure the provision of off-street parking is subject to considerations of urban design, streetscape and heritage conservation.
- (b) To balance car parking provision and access with urban design and amenity outcomes.

Controls

- (a) A Streetscape Analysis is to be submitted in accordance with the *Waverley Development Application Guide*.
- (b) Where off street parking is not characteristic of the streetscape, vehicular access from the street is not permitted.
- (c) Car parking and vehicular access must not dominate the streetscape. Landscaping is to be used to soften the impact of such structures/areas.
- (d) Car parking and driveway design is to preserve mature or significant trees and vegetation on the site and in the surrounding streetscape. A significant tree refers to a tree identified on the Waverley Significant Tree Register, or a tree or vegetation that forms part of a Heritage Item or is within a Heritage Conservation Area.
- (e) Existing natural rock faces and heritage listed sandstone walls must not be removed for the purpose of car parking.
- (f) Entry gates and structures for car parking should be an open design to allow for improved security by way of street surveillance and to reduce any impact on the streetscape.
- (g) Parking structures are to maximise natural light and ventilation.
- (h) Separate and clearly differentiate pedestrian and vehicle access to the site.
- (i) Basement parking areas and structures:
 - (i) In Bondi Junction must not protrude above the level of the adjacent street or public domain;
 - (ii) In other areas, must not protrude more than 1.2m above the level of the adjacent street or public domain.
- (j) Where visible, basement structures and vent grills are to be integrated into the building and landscape design. Ventilation grills are to block views into basement areas and where possible be screened by landscaping in garden beds with a minimum soil plan depth of 1m.

7.2 ON-SITE PARKING

Waverley is divided into two Parking Provision Zones based on proximity to existing public transport services, proximity to services and where the provision of parking is constrained. These zones are summarised in Table 3 and available via Council’s Online Mapping Tool.

Waverley Online Mapping Tool	
https://discover.waverley.nsw.gov.au/	
Map Configuration	Planning
Layer	Parking Provision Zone

Parking Zone	Description	Location	Rate of Provision
1	High accessibility to public transport and services, high density and prone to traffic congestion.	Within 800m of Bondi Junction railway station where multi-residential development is permissible.	Low
2	Good to fair accessibility to public transport and services, mainly low and medium density, with some high density, and varied on-street parking pressures.	Properties outside Zone 1.	Moderate

Table 3 Parking Provision Zones

Objectives

- (a) To ensure on-site parking is usable, safe and integrated into the design of the building.

Controls

- (a) Car park design must be in accordance with relevant Australian Standards.
- (b) Car space dimension, driveway grades, vehicular ramp width/grades and passing bays must be in accordance with the relevant Australian Standards. Car parking spaces are not to unduly exceed typical widths in Australian Standards.
- (c) Vertically stacked parking is only permitted where site constraints (such as horizontal dimensions or vertical relief) prevent full provision of conventional parking.
- (d) Stacked parking spaces are to comply with the dimensions for individual spaces and are not acceptable for visitor parking. The templates provided in Australian Standards indicate the paths swept by maneuvering vehicles and must be used by applicants to design access to parking and loading facilities. A minimum clearance of 300mm between the swept path and any building and obstruction is to be maintained.
- (e) Consolidate basement car parking areas under building footprints to maximise the area available for soft landscaping.
- (f) Design parking structures that minimise reliance on artificial lighting and mechanical ventilation.
- (g) Provide marked pedestrian pathways with clear lines of sight and safe lighting.

- (h) Parking areas must not be located within the front building setbacks for new development.

7.2.1 Vehicle Access

Objectives

- (a) To prioritise pedestrian movements and the public domain over vehicular access.
- (b) To design vehicle access to required safety and traffic management standards.
- (c) To minimise the impact of vehicle access points and driveway crossovers to retain streetscape continuity and reinforce a high quality public domain.
- (d) To ensure vehicle entry points are integrated into building design and contribute to high quality architecture.
- (e) To integrate vehicle access with site planning and local traffic patterns.
- (f) To minimise potential conflict between vehicles and pedestrians.
- (g) To minimise the size and quantity and visual intrusion of vehicle access points.

Controls

- (a) One vehicle access point per development (including any access for service vehicles and parking for non-residential uses within mixed use developments) is permitted.
- (b) Vehicle access is to be from lanes and secondary streets where available, and not from primary street fronts or streets with major pedestrian activity.
- (c) Vehicle access points are to be integrated into the building design.
- (d) Vehicle access is to be designed to minimise the impact on the street, site layout and the building façade design.
- (e) Doors to vehicle access points are to be tilting doors fitted behind the building façade and to be of materials that integrate with the design of the building and contribute to a positive public domain.
- (f) Vehicle entries are to have high quality finishes and detailing. No service ducts or pipes are to be visible from the street.
- (g) Vehicle access may not be required for, or may be denied to some heritage buildings, , and developments where this is uncharacteristic of the streetscape.
- (h) New developments are to utilise existing vehicle access points in adjoining developments where possible, and provide shared access where they are being concurrently developed.
- (i) New developments are to provide vehicle access points that are capable of underground shared access at a later date. Internal on-site signal equipment is to be used to allow for safe shared access.
- (j) Vehicle access should be:
 - (i) Located taking into account any services within the road reserve, such as power poles, drainage inlet pits and existing street trees and adhere to any required clearances
 - (ii) Located a minimum of 10m from the intersection of the two tangent points of the intersecting kerb faces of any two roads and otherwise not located within any exclusion zone per Australian Standards
 - (iii) Locate vehicle access a minimum of 3m from pedestrian entrances.
- (k) Wherever practicable, vehicle access is to be a single lane crossing with a maximum width of 3.0m over the footpath, and perpendicular to the kerb alignment. In exceptional circumstances, a double lane crossing with a maximum width of 5.4m may be permitted for safety reasons.

- (l) Driveway widths must comply with the relevant Australian Standards.
- (m) Car space dimension, driveway grades, vehicular ramp width/grades and passing bays must be in accordance with the relevant Australian Standards.
- (n) Vehicle access ramps parallel to the street frontage will not be permitted.
- (o) Vehicular access must not ramp along boundary alignments edging the public domain, streets, lanes parks, water frontages and the like.
- (p) Access ways to underground parking should not be located adjacent to doors or windows of the habitable rooms of any residential development.

7.2.2 Car Parking Provision Rates

Objectives

- (a) To provide car parking rates which reflect the proximity of development to existing public transport, services and the availability of on-street parking.
- (b) To balance the need to meet parking demand on site with the need to contain parking and promote sustainable transport.
- (c) To establish controls for parking that reflect the characteristics of the area in terms of urban form, land use and proximity to public transport.

Controls

- (a) Approval for on-site parking will only be granted where the site and locality conditions permit.
- (b) Car parking must be designed to complement the design of the building and streetscape to which it relates and incorporate a range of appropriate materials and design.
- (c) Car parking structures are to be located behind the front building line to reduce visual impact upon the streetscape.
- (d) Driveways and vehicular access should be designed to minimise the loss of on-street parking wherever possible.
- (e) Car park access is to be provided from secondary streets or lanes where possible.
- (f) Adjacent properties are to share driveways and vehicle crossings where possible to minimise service entries and increase safety for pedestrians.
- (g) Where a DA involves a change of use, the parking rate for the new use is to be calculated as the difference between the parking rates required for both the present and proposed uses (under this Part). Council reserves the right to require a parking provision rate based on the total requirement for the use if, in its opinion, the DA involves a re-construction of the building.
- (h) When calculating the provision of parking spaces or loading facilities, the following method is to be applied:
 - (i) The number of spaces for each use on the site is to be calculated separately; and
 - (ii) The total number of facilities or spaces to be provided is to be rounded to the nearest whole number, i.e. 2.15 spaces equals a requirement for 2 spaces and 2.50 spaces equals a requirement for 3 spaces.

Car parking rates are developed in line with the most recently published Transport for New South Wales guidelines relating to transport impact assessment
- (i) For developments requiring more than 50 car parking spaces, a maximum of 2% of the required parking spaces may be specified as "small car spaces", with a minimum

length of 5 metres. Such spaces are to be indicated on the plans submitted and clearly indicated when completed.

- (j) Council may also require on-site parking provision be reduced or removed for development fronting secondary streets or laneways in Centres to achieve the relevant objectives of *Part E Site Specific Development*. The exact reduction in on-site parking provision will be determined by Council on a case-by-case basis. Developments that have a single frontage to a primary street will not be permitted on-site parking.

Note: Gross Floor Area is defined as per the definitions in the WLEP, with ‘car parking’ and ‘access to that car parking’ in the WLEP definition referring to the minimum dimensions and access required in order to comply with requirements of AS2890 and the National Construction Code (NCC) – Building Code of Australia (BCA). Car parking spaces above the ‘maximum’ stated in the below table, and components of parking and access areas greater than the minimum dimensions required to meet the AS2890 and the BCC/BCA will contribute to the Gross Floor Area calculation.

Land Use	Parking Zone 1	Parking Zone 2
Private Vehicle Parking		
<i>Low Density Residential parking space rate per dwelling</i>	≤2 Bedrooms – <i>Maximum 1</i> ≥3 Bedrooms – <i>Maximum 2</i>	≤2 Bedrooms – <i>Maximum 1</i> ≥3 Bedrooms – <i>Maximum 2</i>
<i>Medium density residential (3-19 dwellings) parking space rate per dwelling</i>	<i>Minimum - 0</i> <i>Maximum</i>	<i>Minimum - 0</i> <i>Maximum</i>
Studio	0	0
1 bedroom	0.4	1.0
2 bedroom	0.7	1.2
3 bedroom +	1.2	1.5
Visitor	3-6 Units – 0 spaces 7+ Units – 1 space per 7 units	3-4 Units – 0 spaces 5+ Units – 1 space per 5 units
<i>High density residential (20+ dwellings) parking space rate per dwelling</i>	<i>Minimum - 0</i> <i>Maximum</i>	<i>Minimum - 0</i> <i>Maximum</i>
Studio	0	0
1 bedroom	0.4	0.6
2 bedroom	0.7	0.9
3 bedroom +	1.2	1.4
Visitor	3-6 Units – 0 spaces 7+ Units – 1 space per 7 units	3-4 Units – 0 spaces 5+ Units – 1 space per 5 units
<i>Business and office premises</i>	Minimum 0 Maximum 0.66/100m ² GFA	Minimum 0 Maximum 1.0/100m ² GFA
<i>Retail premises</i>	Minimum 0 Maximum 2.0/100m ² GFA	Minimum 0 Maximum 3.3/100m ² GFA
Other Parking		
<i>Motorcycles</i>	1 motorcycle parking bay per 3 car parking bays (including visitor)	
<i>Car Share</i>	A minimum of 1 car share space is to be provided for every 90 residential units. A minimum of 1 car share space be provided for every 50 commercial car parking spaces. 1 car share space can be provided in lieu of 4 car spaces.	
<i>Accessible Car Parking Spaces</i>	A minimum of 1 accessible car parking space is to be provided for every adaptable residential unit and be a part lot in the strata plan.	

	For non-adaptable residential units, if car parking spaces are provided, then a minimum 10% of all car spaces need to be accessible car parking spaces.
--	---

Table 4 Car Parking Rates

7.2.3 Variations to Parking Rates

- (a) Variations to the relevant parking standards will only be accepted where the applicant can demonstrate that the requirement cannot be reasonably achieved (provision of less than the standard); or that exceeding the standard is in the public interest.

Matters that the Council may consider in assessing variations include, but are not limited to, any of the following as are relevant:

- Particular site design requirements such as setbacks, landscaping, solar access and streetscape controls.
- Site and building constraints such as the physical and topographical nature of the site.
- Impacts of any increased building bulk on the streetscape or adjoining land, including overshadowing and loss of views.
- Compliance with deep soil landscape area requirements (side and rear boundary setbacks).
- Impacts of excavation, including land form, structural integrity of buildings and structures on adjoining land, and stability of land on the subject site and adjoining sites.
- Impacts from any increase in hard surface driveways and the building footprint on the availability of water permeable ground spaces.

- (b) Variations to the car parking standards will only be supported where the applicant can demonstrate that the development is unlikely to create significant additional demand for on-street car parking in surrounding streets.

When a development application seeks to vary the car parking provisions, the following priority is to be adopted:

1. Residential parking
2. Visitor parking
3. Commercial Parking (i.e. business, office, retail).

7.2.4 Parking for Low Density Residential Development

Controls

- (a) For new dwellings, car parking should not exceed the rates outlined in Table 4.
- (b) Notwithstanding the above, a reduced rate (or no parking) may be required in the following circumstances, where:
 - (i) Parking may have a detrimental impact on the character of the streetscape, heritage item or heritage conservation area, or health of a mature or significant tree.
 - (ii) A driveway cannot comply with maximum gradients and design standards required by the Australian Standards.
 - (iii) Vehicle entry and exit may have a detrimental impact on pedestrian and traffic movements and safety or nearby services or infrastructure.
 - (iv) The access to the on-site car parking will result in the loss of more than 1 on-street car parking space or equivalent available kerb space, as measured cumulatively along the entire block..
 - (v) The streetscape has limited existing off-street vehicular access and/or consists of a narrow carriageway that does not facilitate efficient vehicular turning movements into off street car parking areas (three or less movements).
 - (vi) There is low on-street parking availability and no net car parking public benefit.
- (c) Where an applicant proposes to provide more than the number of on-site car spaces specified in (a) the additional spaces will contribute to the Gross Floor Area calculation and additional justification must be provided to cover matters such as, but not limited to the impact of:
 - (i) Parking compared to alternatives such as landscaping;
 - (ii) Any increased building bulk on the streetscape;
 - (iii) Any increased building bulk on the amenity of adjoining properties;
 - (iv) The loss of existing on-street parking illustrating existing and proposed off street parking;
 - (v) The level and impact of any excavation; and
 - (vi) Access to public transport.

7.2.5 Motorcycle parking

Objectives

- (a) To encourage alternative forms of transport.
- (b) To ensure the quantity of motorcycle parking available is enough to meet growing demand.

Controls

- (a) Motorcycle parking spaces are to have dimensions of 1.1m x 2.5m.
- (b) Motorcycle parking is to be provided in accordance with Table 4.
- (c) Motorcycle spaces are to be indicated on the plans submitted, and clearly identified for motorcycle use only when the development is completed.

7.2.6 Bicycle Parking

This part should be read in conjunction with *AS2890.3.2015 Parking Facilities – Part 3: Bicycle parking* and the *Bicycle Parking Facilities: Updating the Austroads Guide to Traffic Management*.

Objectives

- (a) To provide safe and convenient end of trip facilities for residents as well as commuters and employees.
- (b) To ensure the quantity of bicycle parking available is sufficient to meet growing demand.
- (c) To promote cycling as a healthy and environmentally friendly way to make commuter, shopping and recreational trips.
- (d) To prioritise the location and design of bicycle parking facilities within parking areas of developments.
- (e) To balance ease of use and convenience with security.
- (f) To promote innovative approaches to providing high-quality and attractive bicycle facilities.

Controls

- (a) Parking for bikes is to be provided at the minimum rates outlined in Table 4, except where an apartment in a residential building has a basement storage area on title that is large enough to accommodate a Class 1 bike locker.
- (b) Areas for bicycle parking will not be included as part of gross floor area or gross leasable area (GLA) for the purpose of calculating car parking provision.
- (c) Council reserves the right to require a greater provision of bicycle parking than indicated in Table 5, where in Council's opinion, the particular nature of the development will generate an increased demand for bicycle parking. This is a particular consideration in areas located close to the bicycle network, and areas of higher density.
- (d) Bicycle parking is to be provided in accordance with requirements for layout, design and security as set out in the Australian Standard AS 2890.3-2015- Part 3: Bicycle Parking, and with regards to the appropriate Security Class, ensuring the required parking space envelope is provided for all Security Levels. Security Class B spaces must be shown on architectural plans, and provide:
 - A secure room(s) or structures (s).
 - Convenient entrance/exit doors, such as sliding doors.
 - Indicative parking layouts including aisles and parking configurations, and the overall area allocated.
- (e) Bicycle parking is to be located:
 - (i) Close to street level entry/exit points; and
 - (ii) Subject to security camera surveillance where such security systems exist.
 - (iii) In visible, easily accessible areas of the building, and at ground level or the first level of any multilevel car parking in its entirety.
- (f) A safe path of travel from bike parking areas to entry/exit points is to be marked.
- (g) Access to bike parking areas are to be:

- (i) A minimum of 1.8m wide to allow pedestrians and bikes to pass each other (access ways can be shared with vehicles within buildings and at entries to buildings, for larger developments a dedicated ramp may be required);
 - (ii) Accessible via a ramp;
 - (iii) Clearly identified by signage; and
 - (iv) Accessible via appropriate security / intercom systems.
- (h) Bicycle parking for visitors is to be provided in an accessible on-grade location near a major public entrance to the development and is to be signposted.
- (i) For retail premises provide the required bicycle parking at an accessible location near the entry to the retail premises.
- (j) For non-residential uses, the following additional end-of-trip facilities are to be provided at the following rates:
- (i) 1 personal locker for each bike parking space;
 - (ii) 1 shower/change cubicle for up to 10 bike parking spaces;
 - (iii) 2 shower/change cubicles for 11 to 20 bike parking spaces are provided;
 - (iv) 2 additional showers/cubicles for each additional 20 bike parking spaces or part thereof.
- (k) Locker, change room and shower facilities are to be located close to the bike parking area, entry/exit points, and within an area of security camera surveillance where there are such building security systems.
- (l) Where innovative parking approaches are proposed, including those for cargo bikes or e-bikes, Council may consider variations to bicycle and/or other parking provisions.

Land Use	Bicycle Parking Rates	
	Long-stay / resident/ employee	Short-stay/ Visitor
Residential Development	<p><i>All residential development</i></p> <p>A minimum of 1.25 spaces per 1 bedroom dwelling and an additional 0.25 spaces for each additional bedroom in each dwelling (rounded up to the nearest whole number for residential flat buildings and shop top housing).</p> <p>A maximum of 30% may be vertical or tiered/stacked spaces or be supplied by Security Level A spaces</p>	<p><i>Medium and High Density (3+ dwellings)</i></p> <p>1 space per 5 dwellings (security level C).</p>
Office	<p><i>Employee</i></p> <p>0.5 spaces per 100m² GFA</p>	<p><i>Visitor</i></p> <p>1.25 space per 2000m² GFA</p>
Retail	<p><i>Employee</i></p> <p>0.2 spaces per 100m² NFA</p>	<p><i>Visitor</i></p> <p>0.4 spaces per 100m² GFA</p>
Education (primary, secondary, tertiary)	<p><i>Employee</i></p> <p>0.4 spaces per staff</p>	<p><i>Student</i></p> <p>0.5 spaces per student</p>
Tourist Accommodation	<p><i>Staff and Long Stay</i></p>	<p><i>Visitor</i></p>

	0.1 spaces per staff / long stay visitor	1 space per 10 units
Places of assembly / sports facilities / community centres	<i>Staff</i> 0.15 spaces per staff	<i>Visitor</i> 0.15 spaces per seat (security level C)
Food and drink premises	<i>Staff</i> 0.15 spaces per staff	<i>Visitor</i> 0.15 spaces per seat (security level C)
Healthcare, Childcare, Other	<i>Staff</i> 0.15 spaces per staff	<i>Visitor</i> 0.1 spaces per visitor (security level C)

Table 5 Bicycle parking rates

7.3 LOADING FACILITIES

Objectives

- (a) To balance parking and loading requirements.
- (b) To provide for adequate loading/unloading facilities without impacting upon amenity and safety.
- (c) To ensure that adequate off street loading and servicing facilities are to be provided for all development where regular delivery of goods are made to or from the site.
- (d) To ensure that the number of loading bays to be provided is appropriate for the scale and type of the use proposed.

Controls

- (a) Loading and unloading facilities should be available for all commercial premises. These facilities are to be provided on-site where the provision of such will not adversely affect the character of the streetscape, pedestrian safety or amenity. A nearby off-site loading bay may be negotiated to minimise adverse impacts.
- (b) Where possible access to a loading facility must be provided via a laneway or secondary frontage.
- (c) The number of loading bays shall be determined having regard to the scale and type of uses proposed. In this regard, details of anticipated volumes and frequency of deliveries is to be provided within the Statement of Environmental Effects submitted with the DA. Table 6 provides for minimum loading requirements.
- (d) The following design principles should be considered in the design of loading facilities including:
 - (i) The size and layout of the service area must be designed to facilitate operations relevant to the development;
 - (ii) A service area must be a physically defined area not used for other purposes, such as storage of goods and equipment or parking;
 - (iii) All vehicles must enter and exit the property in a forward direction;
 - (iv) Internal circulation must be adequate for the largest vehicle anticipated to use the site; and
 - (v) Loading facilities must be designed to comply with the requirements of *AS 2890.2 -2002 Part 2: Off-Street Commercial Vehicle Facilities*.
- (e) A development application shall include the following:
 - (i) The class and dimensions, including height, of the design vehicle accessing the service area.
 - (ii) Clearance heights between the access driveway and the loading dock(s).
 - (iii) The dimensions of the loading dock(s).
 - (iv) Swept wheel paths between the access driveway and the loading dock and the required maneuvering areas for both entry and exit movements.

Use	Rate
Offices, commercial premises & professional consulting rooms	1 per 4000m ² up to 20,000m ² plus 1 per 8000m ² thereafter
Residential flat buildings	1 per 50+ dwellings
Retail	1 per 400m ² GFA
Other uses	Merit Assessment

Table 6 Minimum Commercial Loading Rates

7.4 PEDESTRIAN/BICYCLE CIRCULATION AND SAFETY**Objectives**

- (a) To ensure priority is given to pedestrian and bicycle movements.
- (b) To maintain bicycle and pedestrian safety.
- (c) To provide safe and easy access to buildings.
- (d) To provide a safe and accessible public domain.

Controls

- (a) The location of parking spaces is not to obstruct pedestrian and bicycle access to the premises or major pedestrian and cycling routes.
- (b) Within parking areas of more than 10 car spaces, segregated routes for main pedestrian and bicycle movements must be created making use of line marking, pedestrian crossings, signage and where appropriate speed humps.
- (c) Provide safe lighting during the day and night. Utilise motion sensors to minimise power consumption.
- (d) Exit points of parking areas of more than 10 car spaces require the following safety devices installed within the boundary of the property:
 - (i) Two stop signs;
 - (ii) A white, unbroken line at the exit point appropriate to accompany stop signs;
 - (iii) Two fish eye mirrors to improve sighting of pedestrians traversing the public footpath area;
 - (iv) Either a boom gate or a speed hump, or both, within 8 metres of the exit point; and
 - (v) Clear signage and enforcement of an 8 km per hour speed limit and vehicles' lights being left on within the property.

7.5 GREEN TRAVEL PLANS

A Green Travel Plan is a package of actions designed to encourage safe, healthy and sustainable travel options. By reducing car travel, Green Travel Plans can improve health and wellbeing, free up car parking space, and make a positive contribution to the community and the environment.

Objective

- (a) To reduce car dependency and encourage safe, healthy and sustainable travel options.
- (b) To remove barriers to active travel for all users of developments.
- (c) To maximise the number of people who walk, cycle or take public transport to and from the development.

Controls

- (a) A Green Travel Plan or Workplace Travel Plan is mandatory for all developments:
 - (i) With over 2,500m² for office / commercial/ retail land uses;
 - (ii) Including 15 units or more;
 - (iii) Where 50 or more employees are proposed; or
 - (iv) As deemed necessary by Council.
- (b) A Green Travel Plan must include:
 - (i) Targets – this typically includes the reduction of a single occupant car trips to the site for the journey to work and the reduction of business travel.
 - (ii) Travel data – an initial estimate of the number of trips to the site by mode is required.
 - (iii) Measures – a list of specific tools or actions to support and achieve the targets.

For further information on how to prepare a Green Travel Plan or Workplace Travel Plan go to: www.pcal.nsw.gov.au and www.travelsmart.gov.au and the Sustainable Transport Calculator from the Green Building Council of Australia Design & As Built Tool.

7.6 TRAFFIC AND TRANSPORT MANAGEMENT PLANS

A Traffic and Transport Management Plan sets out the procedures to mitigate and minimise the impacts of the development (both construction and operation) on the capacity, performance and safety of the local road network and traffic systems and also addresses the impacts on pedestrians, public transport, parking and cyclists.

Objectives

- (a) To ensure an adequate assessment is made of the traffic and parking impacts of development on the surrounding road network and adequate measures to ameliorate the impacts are considered.

Controls

- (a) A traffic and transport management plan is required to accompany a development application for the following developments:
 - (i) Child care centre;
 - (ii) Residential development over 15 units or more;
 - (iii) Commercial development with over 2,500m²; or
 - (iv) Other development at the discretion of Council.
- (b) The study should provide an assessment of the traffic and parking impacts the development proposal may have on the surrounding road network and must address matters such as:
 - (i) Current on street parking restrictions and availability;
 - (ii) Time of peak demand;
 - (iii) Proportion of people using facilities on site;
 - (iv) Hours of operation;
 - (v) Current traffic conditions;
 - (vi) The likely impact of the proposed development on existing traffic flows and the surrounding street system;
 - (vii) Safety of pedestrian and vehicular movements in and around the centre;
 - (viii) How impacts of drop-off and pick up will be accommodated; and
 - (ix) Deliveries to the site.

7.7 CAR SHARE

Objectives

- (a) To provide off-street parking opportunities for car share groups, in balance with competing parking demands.
- (b) To support alternative methods of transport and reduce the demand on private car ownership.
- (c) To reduce the reliance on private vehicles and the corresponding traffic impact on the road network.
- (d) To increase uptake and awareness of car share schemes.
- (e) To encourage share car schemes to locate within developments to provide easy access for residents and workers.

Controls

- (a) The maximum amount of car parking spaces for a development is inclusive of car sharing spaces.
- (b) Car share parking spaces must be publicly accessible at all times, adequately lit and sign posted and located off the street.
- (c) Car share spaces must be in optimum positions within the parking area to allow ease of access to car share vehicles by residents and the public.
- (d) Where appropriate, Council may consider the provision of on-street car share spaces in lieu of car parking on site.
- (e) Car share spaces must always be under the ownership of a building's Owners' Corporation as common property.
- (f) Car share spaces must be used and have authorised use by car share vehicles only.
- (g) If a car share space is not taken up by a genuine car share provider, the space cannot be permanently or temporarily designated for alternative purposes.

7.8 ELECTRIC VEHICLE CHARGING POINTS

Objectives

- (a) To prepare future buildings for the requirements of electric vehicles.

Controls

- (a) Electric vehicle chargers and Electric Vehicle Ready infrastructure should be installed as per the rates and specifications in Table 7.
- (b) Electric Vehicle Distribution Boards should be installed to achieve the requirements in Table 7.
- (c) All charging point locations are to be identified on CC Plans.
- (d) All charging points are to have clear signage identifying location, any fees and charges and whether the bay is for public or private use only.
- (e) Charging stations should allow for monitoring and individual billing payment through an Open Charge Point Protocol compatible software back end and NMI registered electricity meters.
- (f) All mixed use, commercial and residential flat building development with on-site car parking should provide at least 1 dedicated space and charging point to be used for electric bicycles and mobility scooters.

Definitions

- Electric Vehicle Ready: a dedicated circuit and cable storage for each parking space with power demand management system to enable all circuits to be used simultaneously.
- Electric Vehicle Distribution Board: a distribution board dedicated to EV charging that is capable of supplying at least 50% of EV connections at full power at any one time during off peak periods. The distribution board will be complete with an EV Load Management System and an active suitably sized connection to the main switchboard.
- Charging Station: an electric vehicle charging station with a minimum power output of 7kW single phase.

Building Class	Car Space Type	Minimum Charging Stations Installed (% of spaces)	Minimum Number of EV Ready Spaces (%)	Minimum Current per Space (A)	Minimum Energy Capacity per Space Day = 9am-5pm Night = 11pm-7am (kWh)
Low density residential	Resident	0	100	16	Night 24
Medium and high density residential (3 + dwellings)	Resident	20	100	16	Night 15
	Visitor	100	100	32	Day 15
Boarding houses, co-living, hostels, hotels, motels	Any	20	40	32	Night 48
Business and office premises	Any	20	40	32	Day 15

Retail premises	Any	20	40	32	Day 15
Other premises	Any	20	40	32	Day 15

Table 7 Specifications for electric vehicle chargers, Electric Vehicle Ready infrastructure and Electric Vehicle Distribution Boards. *Note: Requirements are to be rounded to the nearest whole number.*

B8 HERITAGE

This Part applies to all land identified, and land adjacent to site identified, under Schedule 5 of WLEP where development consent is required.

Applicants are advised to refer to the *Waverley Heritage Policy*.

Where there are inconsistencies between this Part and other Parts of this DCP, this *Part B8 Heritage* will prevail. For development within the Charing Cross and Queens Park Heritage Conservation Areas, also refer to Annexures B8-1 and B8-2.

This DCP is consistent with the Australia International Council on Monuments and Sites (ICOMOS) Charter for Conservation of Places of Cultural Significance (The Burra Charter). In the event of any inconsistencies between the Burra Charter and this DCP, this DCP will prevail.

State Heritage Listing

The State Heritage Register maintained by the NSW Department of Planning and Environment Heritage Branch includes items of Local and State Significance. Works to items identified as being of State Significance require a submission to the NSW Heritage office in conjunction with submission of a Development Application to Council.

Listings with the National Trust of NSW

Where a building or conservation area is also listed by the National Trust, it is Council's practice to refer applications to the Trust for comment. Council will consider submissions made by the National Trust however; Council is not obliged to follow the Trust's advice.

National Heritage Register

Where a place or object is included in the Register of the National Estate, Council is the designated consent authority for all identified buildings.

General Objectives

- (a) To provide a framework for heritage and conservation planning in Waverley.
- (b) To provide detailed guidelines to manage change and ensure the preservation of history and heritage in Waverley.
- (c) To ensure that appropriate heritage documentation is provided to inform the assessment of development.
- (d) To ensure that Aboriginal heritage and archaeology are taken into consideration, and respectfully incorporated where appropriate.
- (e) To ensure that development enhances the character and significance of any heritage item, conservation area, artefact or place.
- (f) To ensure development reflects and promotes an understanding and appreciation of heritage significance.
- (g) To promote sustainable development through the retention and repurposing of existing building stock.

8.1 DEFINING HERITAGE

8.1.1 Heritage Items

A heritage item has cultural significance meaning aesthetic, historic, scientific and / or social value for future generations. All heritage items have been assessed as having significance under the criteria established by the NSW Heritage Branch of the Department of Planning and Environment. The basic criteria of assessment include historic, aesthetic, scientific and social significance, rarity and association with institutions, groups or individuals of importance to the community.

Council supports the retention of heritage items in their significant form and setting whilst allowing sympathetic development to occur. As significance includes the setting, grounds and often the interior of buildings these aspects must be addressed in development applications.

Where new buildings or new building work is to be carried out in the context of a heritage site it is important that the character, quality and value of the setting, streetscape and listed item be maintained.

8.1.2 Heritage Conservation Areas

A Heritage Conservation Area contains a group of buildings where historical origins and relationships between various elements create a distinctive character of heritage. The heritage significance may include subdivision and street pattern, form and scale, the consistency of building materials or the common age of the building stock.

Heritage Conservation Areas often contain both Contributory Items and Non Contributory Items. Heritage Conservation Areas respond to natural features including topography, vegetation and views. Such features are considered contributory to the cultural significance of the Heritage Conservation Area and are acknowledged as contributory items. Note, definitions are included at the end of this DCP.

Council encourages the alteration and or replacement of Non Contributory Items in a manner enhancing the defined heritage significance of the Conservation Area. The existence of non-contributory items in a Conservation Area is not considered a basis for the introduction of development which is not cohesive with the identified significance of the Conservation Area.

All new development in a heritage conservation area is treated as 'infill development.' Details of Waverley's Heritage Conservation Areas are provided on Council's website.

8.1.3 Landscape Items and Landscape Conservation Areas

A substantial number of items in Waverley are identified as having Landscape Heritage Significance. These include natural and manmade or cultivated elements both of planted and non-biological forms. Landscape Items and Landscape Conservation Areas are to be treated as are other identified heritage items or conservation areas with any development

required to maintain and enhance the significance of the landscape item or conservation area.

8.1.4 Archaeological Sites

Evidence of past indigenous and non-indigenous land use remains throughout Waverley. Evidence located below ground or concealed within later works is identified as an archaeological site. Many of these sites are identified on the basis of previous land uses providing the potential for discovery of archaeological evidence of past activities. Others contain known subterranean deposits or artefacts identified in the listing.

8.2 DEMOLITION & EXCAVATION

Demolition requires Council consent and supporting documentation in accordance with the Heritage Act 1977.

Objectives

- (a) To ensure both listed items and buildings which contribute to the significance and character of Heritage Conservation Areas are conserved.
- (b) To discourage demolition so as to preserve the value of heritage items and Heritage Conservation Areas for the local community.
- (c) That replacement development enhances the character of the conservation area.

Controls

- (a) Unless identified alternately, heritage listing of buildings encompasses the whole building and site including outbuildings and boundary enclosures.
- (b) Demolition of a heritage item or contributory building in a conservation area will generally not be supported, unless there are overriding reasons such as extreme structural damage.
- (c) Demolition of a non-contributory building that detracts from a Conservation Area and replacement with an appropriately designed infill building is generally supported provided the proposed infill development is consistent with the objectives and controls outlined in this Part.
- (d) Excavation beneath and/or adjacent to heritage items and/or buildings in heritage conservation areas will only be permitted if it is supported by both a Geotechnical Engineering report and a Structural Engineering report.
- (e) Excavation will not be permitted if:
 - (i) It will occur under common walls and footings to common walls, or freestanding boundary walls, or under any other part of adjoining land; or
 - (ii) It will occur under or forward of the front facade.

8.3 ABORIGINAL SITES

The *National Parks and Wildlife Act 1974 (NPW Act)* is the primary legislation for the protection of some aspects of Aboriginal cultural heritage in New South Wales. Under the *NPW Act*, anyone carrying out an activity must exercise due diligence to determine whether they should apply for consent in the form of an Aboriginal Heritage Impact Permit (AHIP).

The Due Diligence Code of Practice for the Protection of Aboriginal Objects in New South Wales sets out the steps to be taken in order to:

- Identify whether or not Aboriginal objects are, or are likely to be, present in an area
- Determine whether or not activities are likely to harm Aboriginal objects (if present)
- Determine whether an application for an AHIP is required.

A number of Aboriginal cultural heritage sites occur within Waverley and have been included within the WLEP. Further information on Waverley's Aboriginal Cultural Heritage can be found in the Waverley Aboriginal Cultural Heritage Study on the Council website.

As per WLEP clause 5.10, development consent is required to disturb or excavate an Aboriginal place of heritage significance, land known to contain Aboriginal objects, or land which is suspected to contain Aboriginal objects. This Part provides controls to ensure the ongoing management of these sites (refer to Figure 20).

Objectives

- (a) To effectively manage and protect currently identified Aboriginal heritage sites.
- (b) To protect any undetected aboriginal heritage sites.

Controls

- (a) Development on land where there is an identified Aboriginal object as identified in WLEP; is likely to be an Aboriginal object; or is an Aboriginal place of heritage significance; must be supported by an Aboriginal cultural heritage assessment prepared in accordance with the requirements of the *NPW Act* and include appropriate recommendations to inform the long term management of the item of significance.
- (b) Development must be in accordance with Table 8.
- (c) An applicant must refer to the *NPW Act* should an Aboriginal object(s) be discovered when undertaking development.

Site category	Action required
<p>High sensitivity: Sites identified in the LEP as containing an Aboriginal object or Aboriginal Place of heritage significance, or relatively undisturbed areas where artefacts are most likely located.</p>	<p>(a) Due diligence must be exercised to determine whether an AHIP is required. (b) Development consent required.</p>
<p>Low sensitivity: Any area with outcropping sandstone, undeveloped natural landscape or the Bondi Rose-Bay Sand body.</p>	<p>(c) Due diligence must be exercised to determine whether an AHIP is required.</p>
<p>Little likelihood: All areas not included in one of the categories above.</p>	<p>(d) No pre-emptive action required.</p>

Table 8: Guideline for Aboriginal Cultural Heritage and Development

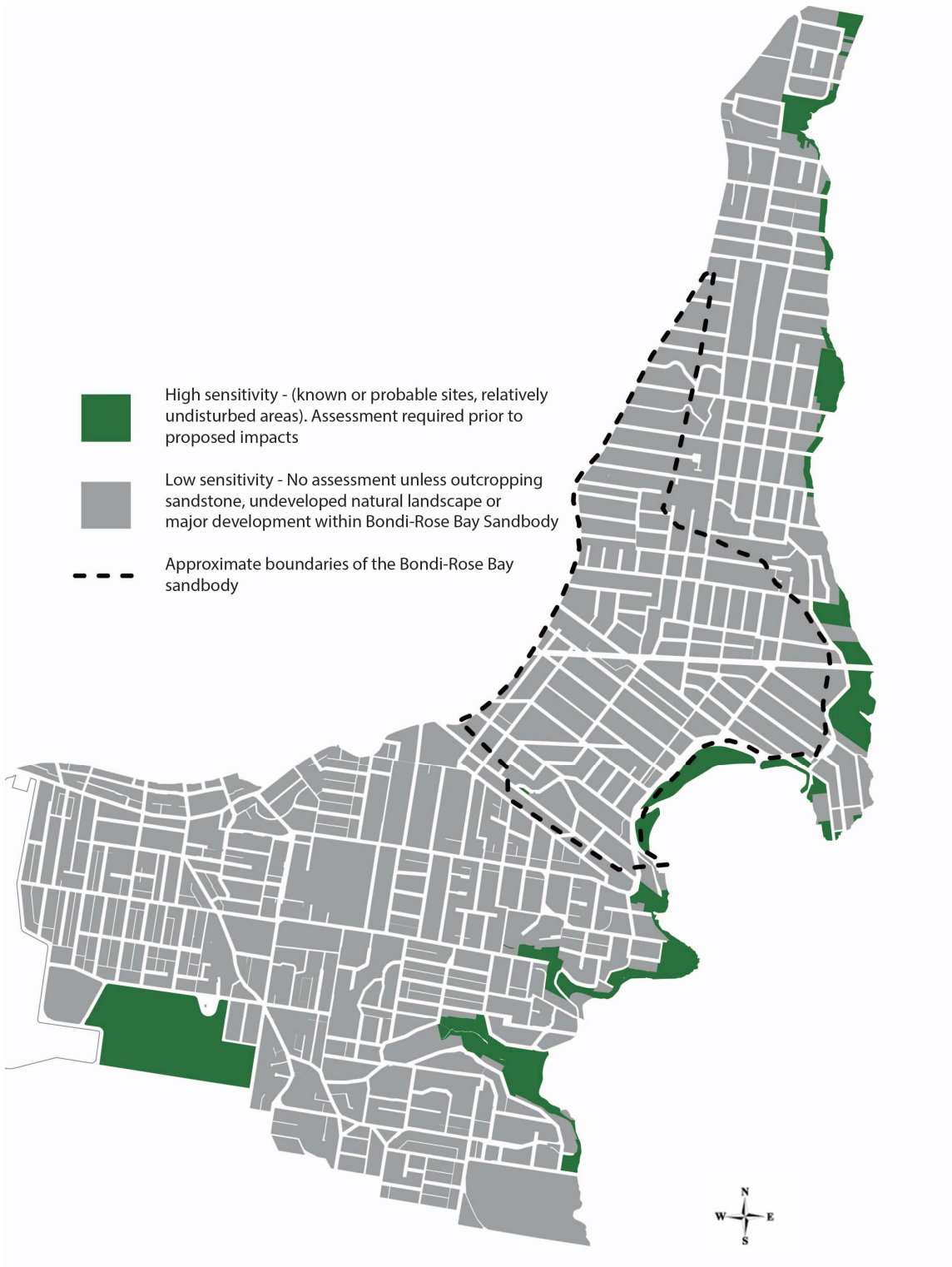

8.4 HERITAGE CONSERVATION AREAS

Objectives

- (a) To promote high quality design that respects and enhances the heritage significance of the conservation area.
- (b) To ensure that development respects the original built form, architectural style and character of the conservation area.
- (c) To ensure that contributory items are retained and improved.
- (d) To promote development that will remove uncharacteristic items, or reduce the extent of their intrusion.

Controls

- (a) Development must demonstrate that it achieves any recommendations for the area as detailed in *Annexure B8-1*.
- (b) Development is to be compatible with the surrounding built form and urban development pattern by addressing the Statement of Significance outlined in *Annexure B8-1*.
- (c) A Context and Streetscape Analysis is to be provided that identifies common elements and features of the area including:
 - (i) Topography and landscape;
 - (ii) Views to and from the site;
 - (iii) Significant subdivision patterns, layout, front and side setbacks;
 - (iv) The type, siting, form, height, bulk, roofscape, scale, materials and details of adjoining or nearby contributory buildings;
 - (v) The interface between the public domain and building alignments and property boundaries; and
 - (vi) Colour schemes that have a hue and tonal relationship with traditional colour schemes.
- (d) Contemporary design is encouraged and is to incorporate the elements and features as identified in the Context and Streetscape Analysis.
- (e) New development is not to be designed as a copy or replica of other buildings in the area.
- (f) Development must not include garages or car access to the front elevation of the development where these are not characteristic of the area.
- (g) The removal of significant public domain features will only be considered if their retention in situ is not feasible and has been demonstrated in a Heritage Impact Statement.
- (h) Building services including air conditioning units, satellite dishes and aerials are not to be visible from the streetscape.
- (i) If significant public domain features are to be removed, they are to be replaced in one of the following ways:
 - (i) Detailed and made of materials to match the period and character of the street or park in which they are located; or
 - (ii) A contemporary interpretation of traditional elements.

8.5 LANDSCAPE CONSERVATION AREAS

Where a place or object is included in the National Heritage List, development and building approval will be required for major work under the Environmental Planning and Assessment Act 1979 (EP&A Act). Waverley Council is the consent authority, however referral to the Australian Heritage Council under the Environmental Protection and Biodiversity Act 2012 is required if the proposal is likely to negatively impact on the National Heritage values.

Objective

- (a) Retain all aspects of Landscape Conservation Areas that contribute to the identified heritage significance of the area.

Controls

- (a) New works in the vicinity of Landscape Conservation Areas and natural settings are to acknowledge the significant character, detail and context of the setting.
- (b) Any new works must consider the visual and physical impact upon the setting.
- (c) Any new work should avoid the removal of fabric whether plant material, manmade feature or natural formation and any works likely to cause long or short term impact upon the setting e.g. change in ground water flow, reflected light, illumination of natural planting and stability of natural or manmade features.
- (d) The removal of significant public domain features will only be considered if their retention in situ is not feasible and has been demonstrated in a Heritage Impact Statement.
- (e) If significant public domain features are to be removed, they are to be replaced in one of the following ways:
 - (i) Detailed and made of materials to match the period and character of the street or park in which they are located; or
 - (ii) A contemporary interpretation of traditional elements.

8.6 CHARACTER AND STREETScape

Objectives

- (a) To reinforce the existing street character, through appropriate dwelling facades, building setbacks, fence and landscaping.
- (b) To ensure that alterations and additions to the external appearance of heritage items and contributory buildings respect the contributory features and characteristics of the existing building and streetscape.
- (c) To allow infill development that respects and complements the existing character of the area.
- (d) To reinforce existing views along streets and from the public domain.

Controls

8.6.1 All Development

- (a) A Context and Streetscape Analysis is to be provided that identifies common elements and features of the area including:
 - i. Topography and landscape;
 - ii. Views to and from the site;
 - iii. Significant subdivision patterns, layout, front and side setbacks;
 - iv. The type, siting, form, height, bulk, roofscape, scale, materials and details of adjoining or nearby contributory buildings;
 - v. The interface between the public domain and building alignments and property boundaries; and
 - vi. Colour schemes that have a hue and tonal relationship with traditional colour schemes.
- (b) Development should identify and respect the contributory features and characteristics of the item or the conservation area and incorporate these features into the design.
- (c) The established landscape character of the locality including the height of canopy and density of landscaping should be retained.
- (d) Development near a heritage item should respect the visual curtilage of the item.

8.6.2 Heritage Items and Contributory Buildings

- (a) Additions should be located to the rear to minimise the impact from the street (refer to Figure 7).
- (b) Where the building form, detailing or use of individual buildings of historic character have been inappropriately altered and changed, any application to upgrade or re-use the buildings must clearly demonstrate that the architectural and streetscape value of the building will be enhanced by the proposal.



Figure 7 Sympathetic additions located to the rear

8.6.3 Infill Development

- (a) New development and alterations and additions to existing dwellings should be compatible and consistent with development both in the immediate vicinity and in the overall context of the street.
- (b) Contemporary design is acceptable in a conservation area where it is sympathetic to, and respects the context of the conservation area and any heritage item in the vicinity (refer to Figure 8).
- (c) New buildings adjacent to buildings of historic character or heritage items should be secondary in prominence to the existing streetscape fabric and draw on the predominant pattern of the existing streetscape.
- (d) Where properties have side street or rear lane frontages, alterations and additions reinforce the desirable side or rear streetscape.
- (e) Appropriate landscape species and plantings are used to reinforce and frame existing vistas, particularly in the typical north-south street corridors.



Figure 8 Sympathetic infill development

8.7 SITING

Objectives

- (a) To ensure that the existing heritage character of the streetscape including setbacks, siting and landscaping is maintained.
- (b) To maintain the general pattern of setbacks within a street.
- (c) To ensure that adequate curtilage and landscape setting is provided.
- (d) To ensure that the siting of alterations and additions to existing and new buildings retains the integrity of the heritage item, its setting, and the conservation area.

Controls

8.7.1 All Development

- (a) Development should conform to the predominant front setbacks in the streetscape.
- (b) Front and rear setbacks should ensure the retention of the existing landscape character of the heritage item or conservation area.
- (c) Any significant historical pattern of subdivision and lot sizes is to be retained.
- (d) Development should respect or utilise the topography and existing vegetation of the land such as rock outcrops and mature trees.
- (e) Building setbacks, terraces, balconies and rooflines are to be consistent within the defined street corridor and provide uniformity to a group of attached dwellings, or mirror an attached semi.

8.7.2 Heritage Items and Contributory Buildings

- (a) Extensions should be kept to the rear of the site to minimise the impact upon the streetscape.
- (b) If there is insufficient space for a rear extension, side extensions should be setback as far as possible from the street.
- (c) Subdivision or site amalgamation involving heritage items or contributory buildings should not compromise the setting or curtilage of buildings on or adjoining the site.
- (d) Construction, demolition or modification should not adversely affect the existing setting of the item or area.

8.8 SCALE AND PROPORTION

Objectives

- (a) To ensure that alterations and additions to heritage item and contributory building are consistent with the scale and proportion of the item and/or streetscape.
- (b) To encourage infill development that recognises the predominant scale and proportion of the setting and responds sympathetically.
- (c) To promote development that is respectful of the scale of the surrounding buildings and area.

Controls

8.8.1 Heritage Items and Contributory Buildings

- (a) Alterations and additions should not visually dominate, compete with or conceal the original scale and proportion of the heritage item, contributory building or conservation area.
- (b) Alterations and additions should respect the proportions of major elements including doors, windows, roof forms and verandahs (refer to Figures 9-11).

8.8.2 Infill Development

- (a) Infill development should be cohesive in scale, proportion and finish to the surrounding streetscape and buildings (refer to Figure 12).
- (b) Infill development should maintain and enhance the skyline profiles of established settings.
- (c) Where the scale of the roof is much larger than that of adjacent buildings, the roof should be broken up into smaller elements to reduce bulk.
- (d) Setbacks should be provided to upper levels.

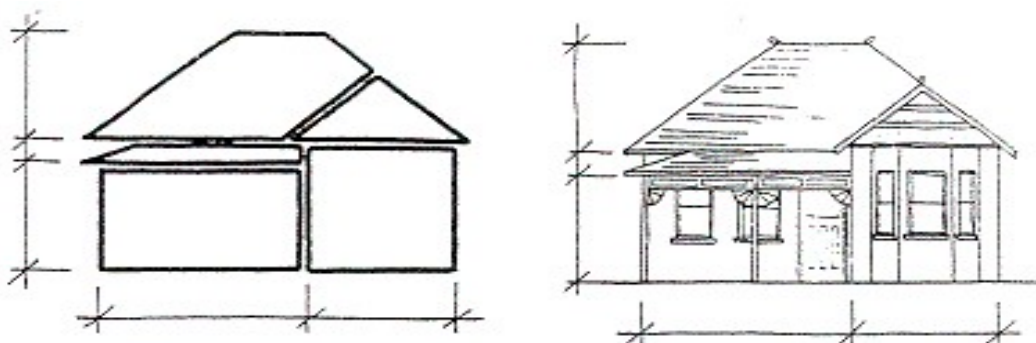

Figure 9 Consideration of scale and proportion

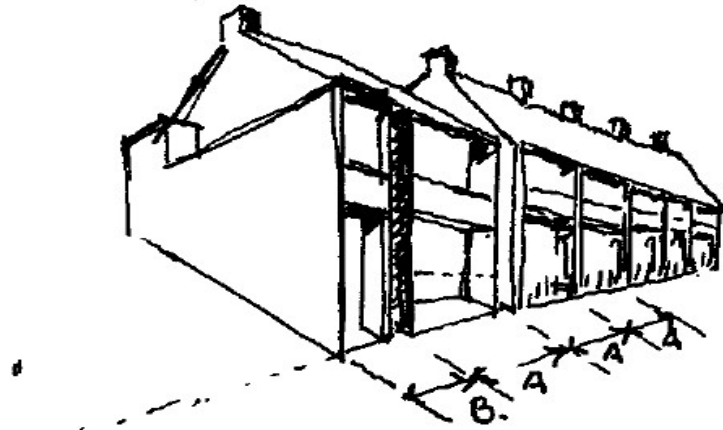

Figure 10 Consideration of scale and proportion within a row of terrace houses



Figure 11 Unsympathetic additions in relationship to the scale of the original dwelling



Figure 12 Sympathetic infill development

8.9 ARCHITECTURAL STYLE

Objectives

- (a) To reinforce the various established architectural styles of dwellings through sensitive alterations and additions and appropriate new developments.
- (b) To emphasise balance and symmetry in alterations and additions to detached, semi-detached and attached dwellings.
- (c) To reinforce the existing pitched roofscape as the desired character of conservation areas and promote consistency in roofing materials.

Controls

- (a) New development is to be sympathetic to the established architectural style in the vicinity and preserve the area's character.
- (b) Where the existing building or structure contributes to a historical or coherent theme of the street, re-use or refurbishment of the existing building is encouraged.
- (c) Alterations and additions to existing dwellings must incorporate appropriate or compatible architectural vocabulary, consistent with the period of the building's original development.
- (d) Where a building sits in a row with similar architectural style and details (such as gable, roofscape, entrance, terrace roof, chimney, windows, door, fences), the bulk and rhythm of these details are to be maintained.
- (e) Where terrace (attached) and semi-detached dwellings have a small front setback, their façade detail and building elements, such as doors, windows, balustrades, mouldings or tiles are to be sensitively integrated with the streetscape character.
- (f) Flat roofs are to be avoided where they detract from the established roof character of the locality. Where they are visible from the street, roofing materials and details shall be compatible with the established streetscape character.

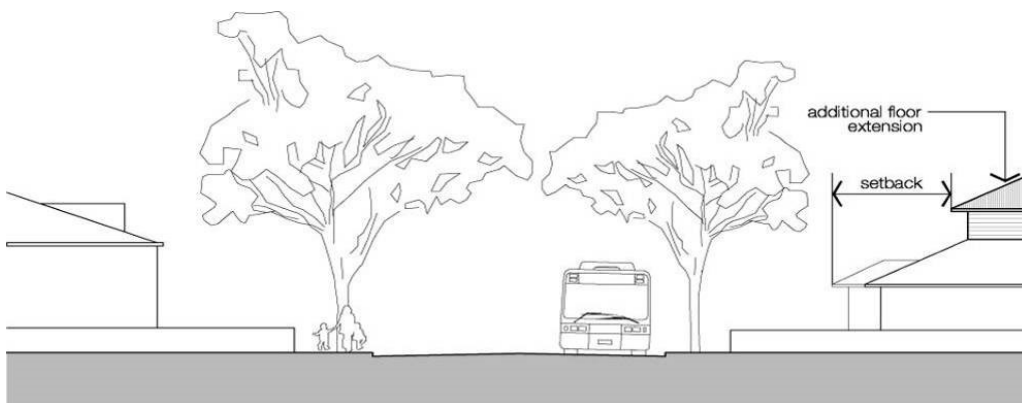

Figure 13 An example of alterations and additions which are sensitively undertaken. First floor additions are set back in order to minimise the impact upon the street character.

8.10 MATERIALS AND COLOUR

Objectives

- (a) To ensure that the selection of materials and colours is harmonious with the item or conservation area.
- (b) To ensure infill development considers the materials and colours characteristic of the conservation area.
- (c) To ensure that detailing and decoration is provided in consistent materials, finishes and colours to listed heritage items and identified conservation areas (refer to *Annexure B8-1*).

Controls

8.10.1 Heritage Items and Contributory Buildings

- (a) Council may require a proposed colour palette to be submitted with the development application.
- (b) Original construction and in particular original finishes are to be maintained where possible.
- (c) Changes to materials on elevations visible from the public domain are discouraged.
- (d) Alterations and additions should use materials similar to or compatible with the original material used.
- (e) The selection of materials and colours is to be consistent with those used in the item or conservation area.
- (f) Colours for alterations and additions should be consistent or harmonious with existing building to help integrate new and old.
- (g) Previously unpainted surfaces should not be painted. Painting of original stone or face brickwork causes fretting and eventually substantial damage as it traps moisture inside. Similarly, clear sealer such as silicone should be avoided.
- (h) Original face brickwork and stonework is not to be rendered.
- (i) Bricks should match the existing brick and mortar colours as well as the type of joint and brick laying pattern.
- (j) New building work constructed of timber should match the existing building elements made of timber (e.g. frames, weatherboarding, fascias, brackets, columns, friezes, etc).
- (k) Cast iron or wrought iron elements, should be reinstated where possible.

8.10.2 Infill Development

- (a) Infill buildings should recognise characteristics materials, textures and colours used locally and in adjacent buildings.
- (b) Materials and colours of surrounding buildings need not be simply copied but used as a point of reference.
- (c) Modern materials can be used if their proportions and details are harmonious within the surrounding historic context.

8.11 ROOFS AND CHIMNEYS

Objective

- (a) To retain and maintain the characteristic roof forms, finishes and chimneys of heritage items and conservation areas.
- (b) To ensure new roof profiles are consistent with the established skyline profiles of the conservation area.

Controls

8.11.1 Heritage Items and Contributory Items

- (a) Skyline profiles of original roofs and chimneys should be retained where possible.
- (b) Original chimneys are to be retained.
- (c) Where chimneys are paired across party walls, treatment of finishes and detailing is to be consistent between properties.
- (d) Substitution of finishes and removal of details including chimneys is only permitted where Council approves a cohesive replacement finish or detail.
- (e) Attic rooms are to be wholly within existing roof forms which retain the streetscape appearance of the existing building.
- (f) Roof extensions are to match the existing roof in form, pitch and eaves and be in proportion with the existing building.
- (g) The use of modern roofing materials is discouraged as they can significantly alter the character of the building.
- (h) New tiles or slates should match the existing tiles/slates as closely as possible and concrete tiles are not considered a suitable replacement material.

8.11.2 Infill Development

- (a) New roof profiles are to be secondary to the established skyline profiles in the Heritage Conservation Area and are to enhance the established character of the existing skyline (refer to Figure 13).

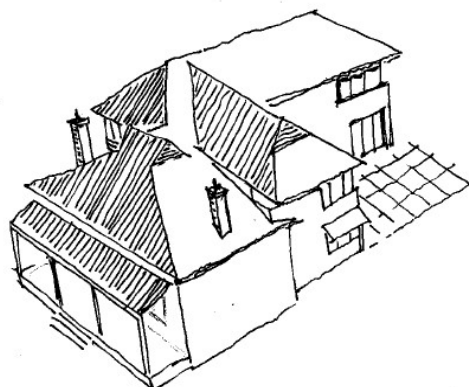

Figure 14 New roof forms are to be secondary to the established skyline profile

8.12 VERANDAHS AND BALCONIES

Objectives

- (a) To ensure the retention and reinstatement of early verandahs and balcony forms.
- (b) To ensure that alterations and additions do not detract from original balconies and verandahs.

Controls

8.12.1 Heritage Items and Contributory Buildings

- (a) All original verandahs and balconies should be retained and restored (refer to Figure 15).
- (b) Infilling or enclosure of verandahs and balconies is not supported.
- (c) Additional verandahs should not compete with an original verandah or balcony.



Figure 15 Original verandahs should be retained

8.13 GARAGES, PARKING AND SITE ACCESS

Objectives

- (a) To retain the heritage character of the streetscape.
- (b) To promote the retention of original front facades, fences, masonry and landscaping that may otherwise be removed for parking.

Controls

8.13.1 All Development

- (a) Where car access is available to the rear or side of a property, parking is not permitted within the property frontage.
- (b) Where rear lane access to a property exists or is provided, garages and driveways are to be located at the rear.
- (c) No part of an existing building is to be demolished or altered in order to accommodate a carport, garage or car space within the front or side setbacks or facades.
- (d) Original fences are not to be removed to create car access from the main street frontage unless there is sufficient space to access a side driveway.
- (e) Car spaces are not supported between a building and the front boundary. Council may consider an unroofed parking space in exceptional circumstances where it is shown that the space does not dominate the setting of the house.
- (f) The form, size, detailing and materials of any new structure are to complement the heritage item, contributory building, or character area.
- (g) Where driveways are permitted, pavement materials should reflect the traditional character of the area. Large areas of continuous concrete or asphalt are not to be used, however these materials may be used in smaller areas if designed in appropriate ways. Preferred materials include dry laid paving. Stenciled concrete is not permitted.

8.13.2 Heritage Items and Contributory Buildings

- (a) Development to Heritage Items and Contributory Buildings must not include garages or driveways to the front of the property.

8.13.3 Infill Development

- (a) Infill Development must not include garages or driveways to the front of the property where these are not characteristic of the area.
- (b) Where no rear lane access is provided and it is consistent with the predominant character of the area, garages should be either setback behind the line of the dwelling frontage, or incorporated within the building design (for new dwellings).
- (c) Where the streetscape is dominated by garages located up to the front boundary, garages may be allowed in front of the dwelling. Driveway width shall be minimised to maximise on street parking availability and landscaping used to unify the garage and dwelling with the landform.

8.14 GARDEN ELEMENTS

Objective

- (a) To ensure that the landscape settings and elements of heritage items or buildings within a conservation area are retained or reinstated.
- (b) To promote the retention of original soft and hard landscaping to maintain the character of the area.
- (c) To promote the retention of coursed local sandstone retaining walls that are characteristic of Waverley's heritage.

Controls

8.14.1 Heritage Items and Contributory Buildings

- (a) Original and contributing elements of hard and soft landscaping are to be retained on heritage listed sites and where occurring in Conservation Areas.
- (b) Where a site contains existing coursed local sandstone retaining walls, the walls are to be retained and incorporated into the overall design.
- (c) High walls or fences and unsympathetic garden treatment (e.g. rockeries, dense plantings that are out of character) are discouraged.
- (d) New hard and soft landscaping is to be provided with regard to the:
 - (i) Stability of existing significant fabric;
 - (ii) Retention and enhancement of original hard and soft landscaping; and
 - (iii) Character of the site and/or Conservation Area.

8.15 BUILDING FACADES

Objective

- (a) To retain the existing façades of original heritage items, contributory buildings or buildings consistent with the character of the area.

Controls

8.15.1 Heritage Items and Contributory Buildings

- (a) Where a building façade provides the core character detail and aesthetic qualities of an item the extent of a cohesive alteration and addition may extend to removal of other areas of the listed structure provided the façade remains in conjunction with a full structural bay or room depth and there remains a cohesive interface of new and existing works.
- (b) Alteration or removal of original facades which are of heritage significance is not supported.
- (c) Proposed works are to be sympathetic to and not detract from the style and character of the building.

8.16 DETAILING

Objectives

- (a) To encourage the retention and maintenance of original detailing to preserve the character and significance of the area or item.
- (b) To ensure alterations and additions have a level of detail that is appropriate to the architectural character and style of the heritage item or conservation area.
- (c) To ensure infill development has regard to the architectural character and style of the conservation area.
- (d) To promote the retention of historic detailing styles and practices.

Controls

8.16.1 All Development

- (a) Landscape details such as fences, garden walls and planting treatment which contribute to the area should be retained where possible.
- (b) New windows should match the existing in size and detail, including the existing sill details, window heads, and stained or patterned glass type. Window should not be enlarged or altered.

8.16.2 Heritage Items and Contributory Buildings

- (a) Development should be designed to enhance original detailing of buildings.
- (b) Original details should be retained and repaired where possible.
- (c) Where original details have been removed or replaced with modern materials, consideration should be given to reinstating original features.
- (d) Decorative elements should not be introduced on heritage items and contributory buildings unless documentation or physical evidence indicates the elements previously existed.
- (e) Alterations and additions should adopt a similar character, which uses external finishes, colours, and textures that complement the heritage fabric, rather than mimic inappropriate decoration or detailing (refer to Figure 16).

8.16.3 Infill Development

- (a) Modern details should defer to, and be cohesive with, traditional details that contribute to the character of the area.



Figure 16 Sympathetic detailing of additions.

8.17 FENCING AND GATES

Objectives

- (a) To ensure new fencing is consistent with, and does not detract from, the heritage item or streetscape.
- (b) To retain, repair and reconstruct original fencing.
- (c) To ensure fencing makes a positive contribution to the character and quality of the street.

Controls

8.17.1 Heritage Items and Contributory Buildings

- (a) Where original fences remain on listed items or within Conservation Areas these are to be retained and enhanced by appropriate maintenance and sympathetic landscaping.
- (b) Planting and maintenance of existing planting is to avoid tree or plant growth that damages existing fences or gates.
- (c) Fences and boundary walls employing masonry (principally stone or face brick) construction are not to be rendered, painted or coated with other materials unless the finish is known to be a detail of the original construction.
- (d) Front fences should not obscure building facades.
- (e) New fence heights and form should be appropriate to the character of the heritage item or to the conservation area.
- (f) Where an original fence has been lost, new fencing should match the original style.
- (g) Sandstone fencing and foundations should be retained and sympathetically incorporated into any new additions or alterations. Restoration/repair of slate/stone must be carried out by specialists.
- (h) Low and transparent fences in front yards are desirable, especially where setbacks are minimal.
- (i) Front fences should be of a low or transparent style and where masonry is used it should be no higher than 600mm, while transparent fences may not exceed 1200mm in height.
- (j) Rear fences should be between 1.8m and 2m in height.

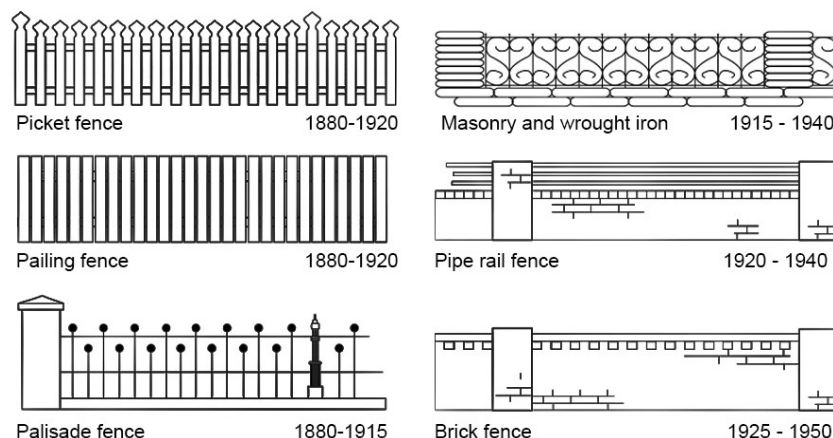

Figure 17 Examples of period fences



Figure 18 Low fences are desirable, especially where setbacks are minimal.

8.18 LANDSCAPING

Objectives

- (a) To conserve the existing inner residential street landscape character and view corridors which have been established by the colonnades and canopy of existing street tree planting.
- (b) To establish soft landscaping at the front setback compatible with the style and character of the area.

Controls

- (a) Unless it is the predominant character, overly dense landscaping or large trees are not desirable in the front setback as they darken the street corridor and undermine the character of the existing street tree plantings (refer to Figure 19).
- (b) On steeply sloping or split level sites landscaping is to be planted so as to allow for a visual connection between the building facades and the street (refer to Figure 20).
- (c) Soft landscaping is used to reinforce important character elements in the front of dwellings, especially detached dwellings and larger sites.

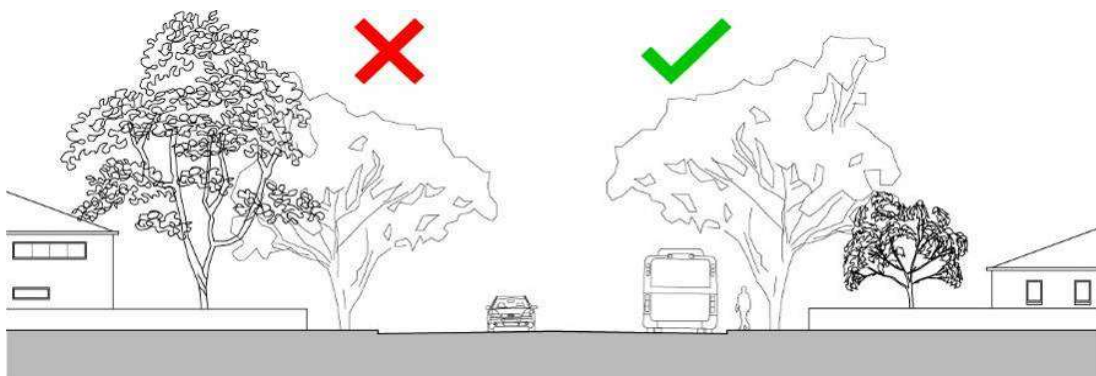

Figure 19 Where mature street trees exist, avoid high and over dense landscaping in the front of dwellings.

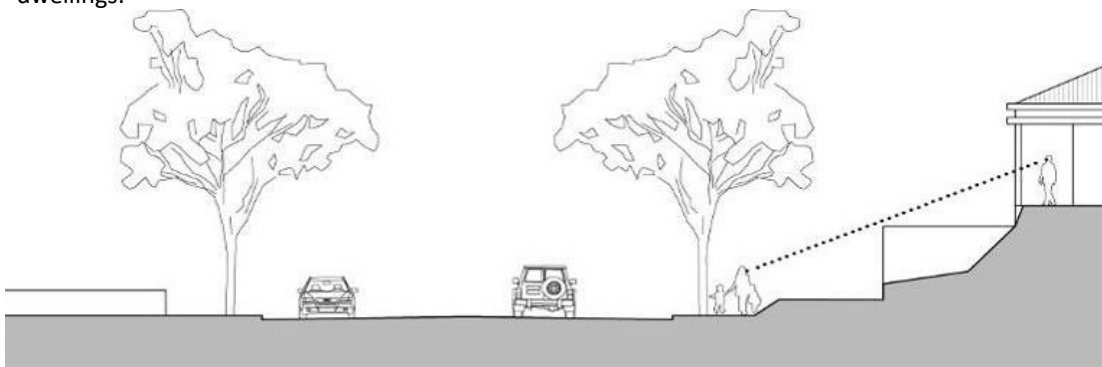

Figure 20 A visual connection to the street is important to cultivate surveillance and is in keeping with the established character.

8.19 SOLAR PANELS

For specific guidance on solar panels in heritage conservation areas, refer to the Solar Panels and Heritage Guidelines and part B2 Ecological Sustainable Development of this DCP.

8.20 COMMERCIAL PROPERTIES

Objective

- (a) To ensure that the original characteristics of traditional neighbourhood retail buildings are retained and enhanced.
- (b) To encourage the retention of distinctive settings of grouped building frontages aligned to the street.
- (c) To promote the retention of distinctive detailing on commercial properties.
- (d) To retain original parapet continuity and detailing.
- (e) To retain architectural features and detailing that characterise the period of development.

Controls

8.19.1 All Development

- (a) Generally, the facade at street alignment shall comprise a canopied shop front at ground level, and first floor facade above the awning.
- (b) The height of the building at the facade shall take into consideration existing parapets and other facade details of established surrounding development.
- (c) Additional floors should be setback from the street alignment to ensure a two storey elevation to the facade is maintained where appropriate (refer to Figure 21).
- (d) Consideration will be given to a variation of the established alignment in the case of a comprehensive development incorporating a pedestrian open space function.
- (e) Developments on corner sites should be designed to accentuate the corner, and provide the transition between one streetscape and the next. Existing corner splays shall be retained.
- (f) Signage shall be restricted to under awning shop fronts, awning fascias and as suspended under awning signs.
- (g) Signage above the awnings shall be limited to appropriate areas allocated for such a purpose in the original facade design (parapets for example).
- (h) Flush mounted, or projecting wall signs shall not be permitted above the awning. Council will give consideration to the architectural qualities of the building when addressing the suitability of the proposed sign.
- (i) Pitched or domed awnings of glass or canvas construction shall not be permitted where they interrupt a run of traditional awnings.

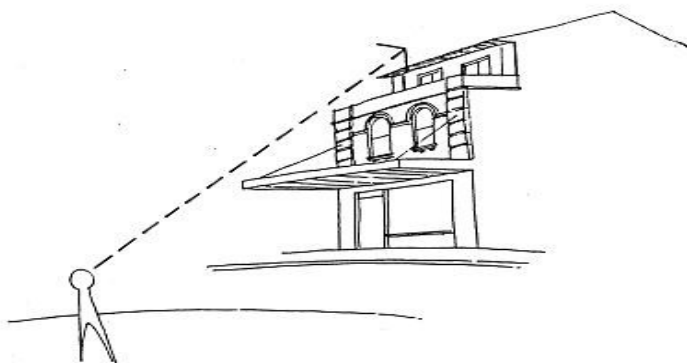

Figure 21 Additional floors should be setback from the street alignment

8.19.2 Heritage Items and Contributory Buildings

- (a) Details of earlier shop front features should be retained.
- (b) The maintenance and restoration of detailing to commercial/retail groups is encouraged (refer to Figure 22).
- (c) Horizontal proportions should be considered both in new development, and in the redevelopment of old facades. Consistency should be achieved through:
 - (i) Parapet height;
 - (ii) String course both at parapet level, and to the remainder of the facade;
 - (iii) Window proportions (sill and lintel height);
 - (iv) Awning height and continuity; and
 - (v) Top hamper proportions and window kick plate height.

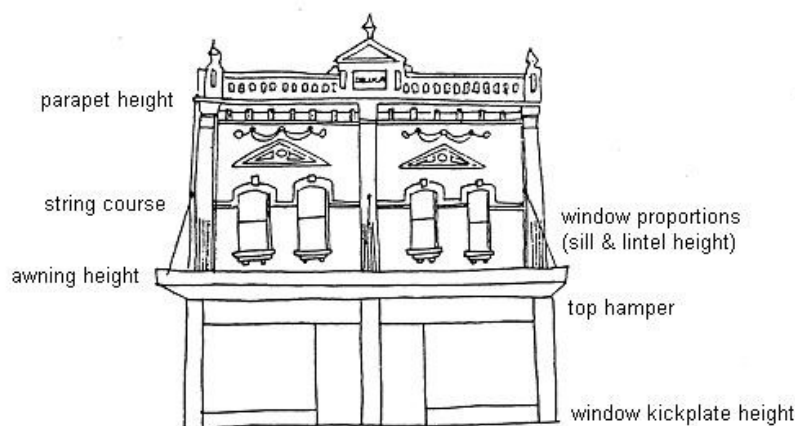

Figure 22 Overall consistent design of elements

- (d) Where shopfront groups are listed as heritage items the following issues are to be considered:
 - (i) The extent and quality of conservation and restoration of street frontages;
 - (ii) The interface of new and existing works; and
 - (iii) The impact of new works on the existing fabric, streetscape and overall setting.
- (e) Where it is proposed to retain the street facade and construct new works to the remainder of the site, assessment will be based upon the above the impact of skyline profiles on the retained façade the setting and the cohesion of the works (refer to Figure 23).

- (f) Existing shop fronts should not be bricked up or replaced by roller shutters.
- (g) Existing box section awnings, either cantilevered, or suspended by tie rods, should be retained.
- (h) New awnings should match the form of adjacent awnings and maintain the same alignment, to ensure unity in streetscape details.
- (i) Reinstatement of balconies and verandahs to street frontages is supported.
- (j) Alterations to individual shop facades above awning level will not be permitted where that facade is part of a homogeneous or symmetrical group of facades.
- (k) A row of shops which are homogeneous or symmetrical in style should adopt a uniform tonal distribution over the facade, without limiting the individual expression of colour on each shop.

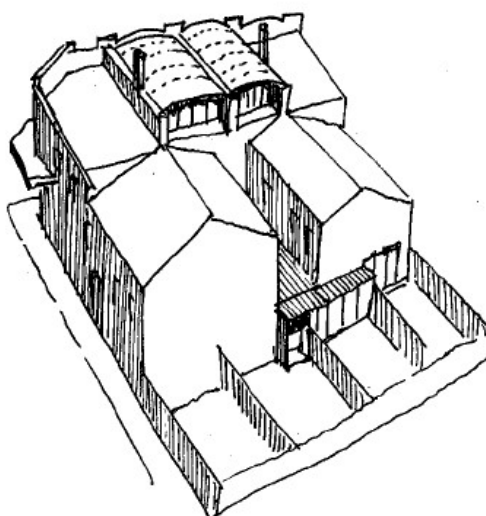

Figure 23 Rear extensions to commercial properties

8.19.3 Infill Development

- (a) New development should conform to the established street front building alignment for the extent of its height.
- (b) New under awning shop fronts should be simply detailed with large areas of glazing and narrow mullions/framing.
- (c) The height of new development at the street alignment should not exceed the height of existing buildings.

B9 SAFETY

The aim of these controls is to ensure that the way in which the site and the buildings within the site are laid out, enhance security and feelings of safety and clearly delineate between private and public space.

This Part should be read in conjunction with NSW Government's Crime Prevention and the Assessment of Development Applications Guidelines under Section 4.15 of the *Environmental Planning and Assessment Act 1979*.

The preparation of a Crime Prevention Through Environmental Design (CPTED) assessment is to be prepared in accordance with the *Waverley Development Application Guide*.

9.1 BUILT FORM

Objectives

- (a) To provide for a safe environment for residents, visitors and workers and minimise the opportunities for criminal and anti-social behaviour.
- (b) To encourage the design and management of the built environment to reduce the opportunity for crime.

Controls

- (a) Maximise casual surveillance by orientating buildings towards the street.
- (b) Active spaces including windows of habitable rooms within the buildings are to be located to maximise casual surveillance of public spaces such as streets, laneways, parking areas and communal areas such as play areas, swimming pools, gardens and the like.
- (c) The design of building details including the provision of fencing, drainpipes and landscaping is to be such that illegitimate access is not facilitated through the creation of footholds, concealment and the like.
- (d) Minimise blind corners, recesses and other external areas which have the potential for concealment.
- (e) Pathways and entries providing access to, around and within the site should be designed to ensure good visibility for and of the user.
- (f) Building entries and mailbox entries are to be clearly visible, easily identifiable from the street and unobstructed.
- (g) Pedestrian routes to and from car parking spaces including to lift lobbies are to be as direct as possible with clear sightlines.
- (h) All entrance and exits, service areas must be clearly identifiable after dark by appropriate lighting.
- (i) All lighting on the site should be designed so it doesn't produce areas of glare and shadow or create a nuisance for neighbours.
- (j) Details of all lighting for public areas must be submitted with a development application for multi-residential development i.e. details of location, type and intensity.

- (k) Fencing which is used to delineate private space is to be used in a way which enhances safety by maximising opportunities for casual surveillance between the dwellings and the street frontage.
- (l) Materials should minimise opportunities for vandalism.
- (m) Flat or porous finishes should be avoided in areas where graffiti is likely to be a problem. Use non-porous material such as glazed ceramics or treated masonry products.
- (n) Where large blank walls are unavoidable, consider the use of a “green screen” i.e. planting vegetation in front of the wall or using vegetation to cover the wall itself. Alternatively use vandal resistant paint or artwork to reduce opportunities for graffiti or articulate or modulate the wall.
- (o) Ensure individual dwellings are equipped with security devices.
- (p) Where public spaces of larger developments could result in the gathering of groups of people, the development may be required to provide CCTV facilities to monitor those areas.

B10 PUBLIC ART

This part applies to new developments and major alterations and additions and is to be read in conjunction with the *Waverley Council Public Art Policy* and the *Waverley Public Art in the Private Domain Guidelines*.

10.1 PUBLIC ART IN THE PRIVATE DOMAIN

Objectives

- (a) To ensure new public spaces include high quality, diverse and creative public art and visual art.
- (b) To encourage developments to contribute to the ongoing development of public art and visual art within Waverley.
- (c) To increase public art in Waverley for greater community cohesion and understanding of the history, culture and place

Controls

- (a) Developments located within an E1, E2 or MU1 zone, with a construction value exceeding \$10 million are required to integrate a public artwork into the development to a minimum value of 1% of the construction costs (excluding administration and associated costs).
- (b) Applicants are encouraged to clarify the value and type of public art during the Pre-Development Application process via the preparation of a Public Art Plan – to be submitted as part of the DA.
- (c) Developments are to incorporate public art in highly visible areas such as public plazas, through site links, and external walls.
- (d) Public art is to be integrated into the architectural integrity of a development.
- (e) All privately commissioned public art must be undertaken in accordance with the *Waverley Public Art in the Private Domain Guidelines*.
- (f) Murals do not require development consent, however must be undertaken in accordance with the *Waverley Public Art in the Private Domain Guidelines*.
- (g) Murals that contain marketing or advertising material, or the like, will be treated as signage, and must seek development consent and comply with the provisions of *Part B14 Advertising and Signage*.
- (h) Artworks on heritage items or within heritage conservation areas must also comply with the provisions of *Part B8 Heritage*.

B11 DESIGN EXCELLENCE

Applicants are to refer to the relevant design excellence policies as produced by the Government Architect New South Wales.

11.1 DESIGN

Objectives

- (a) To ensure development contributes to the architectural and overall urban design quality of Waverley.
- (b) To encourage variety in architectural design and character across large developments.
- (c) To identify the key components of good urban design.
- (d) To increase the value of site and context analysis and promote site specific design responses.

Controls

- (a) Development is to achieve a high standard of architectural design, materials and detailing appropriate to the building type and location.
- (b) The form and external appearance of development is to improve the quality and amenity of the public domain.
- (c) Development is to consider and retain view corridors. Development will not be supported where detrimental impacts upon views and vistas is imposed, particularly those views from the public domain.
- (d) Development must not have a detrimental effect upon the amenity of public plazas and public open spaces.
- (e) Development must consider the following:
 - (i) The suitability of the land for development;
 - (ii) Existing and proposed uses and use mix;
 - (iii) Heritage issues and streetscape constraints;
 - (iv) The relationship of the development to other development (existing or proposed) on the same site or on neighbouring sites in terms of separation, setbacks, amenity, and urban form;
 - (v) Bulk, massing and modulation of buildings;
 - (vi) Street frontage heights;
 - (vii) Environmental impacts such as sustainable design, overshadowing, wind and reflectivity;
 - (viii) The achievement of the principles of ecologically sustainable development;
 - (ix) Pedestrian, cycle, vehicular and service access, circulation requirements; and
 - (x) The impact on, and any proposed improvements to, the public domain.

11.2 CONTEXT ANALYSIS

Objectives

- (a) To increase the value of site and context analysis and promote site specific design responses.
- (b) To ensure that development demonstrates an understanding of an appropriate response to the specific conditions of both the site and surrounds.
- (c) To identify the key contextual features and characteristics of the surrounding urban form to which the design should respond.
- (d) To ensure that the opportunities and constraints of a site are fully considered and incorporated into the design proposal.

Controls

11.2.1 Context Analysis

- (a) A Context Analysis is to include an analysis of the urban form including but not limited to the following:
 - (i) Urban structure - The relationship between buildings, spaces, infrastructure and connections, landform, topography and natural features.
 - (ii) Urban grain - The subdivision pattern, the scale and configuration of streets and lots, and the rhythm of buildings and spaces.
 - (iii) Density and Mix - The amount of development and the range of uses in relation to the site's location and size; and its accessibility and proximity to other uses.
 - (iv) Height and massing - The scale, arrangement, volume and shape of buildings in relation to humans, other buildings, structures, spaces, skylines and views.
 - (v) Building type - The building footprint, its layout, circulation and access, and its functional relationship to adjoining spaces and buildings.
 - (vi) Façade and interface - The relationship and expression of the external faces of the building, its rhythm and pattern of openings, expression of entries, corners and roofscape, setbacks and boundary treatments.
 - (vii) Details and materials - The techniques, craftsmanship and detail of building components, and how the proposed selection of materials relate to the context through colour, pattern and treatment of materials including durability, sustainability and contextual fit.
 - (viii) Streetscape and landscape - The surrounding built and natural context, including street elevation, building typologies and their spatial and locational characteristics, treatment of street/boundary interfaces, microclimate, ecology and biodiversity. Relate the analysis to how the proposed development contributes to the streetscape and landscape of the area.
 - (ix) Social and economic fabric - Non-physical aspects of urban form including the productive capacity and economy of the community, cultural and social factors such as health and wellbeing, and community interaction.

B12 SUBDIVISION

These subdivision provisions supplement the WLEP provisions on minimum lot size. The provisions apply to Torrens Title subdivision, not Strata Title Subdivision.

The WLEP permits subdivision with consent, however applicants should also refer to *State Environmental Planning Policy (Exempt & Complying Development) 2008* which enables some forms of subdivision as exempt or complying development.

Objectives

- (a) To maintain the established character of low density neighbourhoods occupied by dwelling houses, semi-detached dwellings, attached dual occupancies or a mixture of these housing types.
- (b) To ensure that subdivision or amalgamation respects the predominant development pattern of the locality.
- (c) To ensure that subdivision or amalgamation results in allotments that have adequate width and configuration to deliver suitable building design and to maintain the amenity of the neighbouring properties.
- (d) To prevent the fragmentation of land that would prevent the delivery of permitted uses on the lot.
- (e) To ensure that subdivision results in lot sizes that protect natural or cultural features including heritage items, protected ecological communities or species, and retain special features such as trees and views.
- (f) To avoid increasing the community's exposure to coastal hazards by minimising the number of residents living within areas that are at risk from coastal hazards.
- (g) To ensure that subdivision and amalgamation result in lots that can achieve compliance with all other relevant DCP controls.
- (h) To ensure that the creation of new lots does not result in a reduction of pedestrian or vehicular connectivity within the existing street network and provides a safe network.
- (i) To minimise any likely impact of subsequent development on the amenity of neighbouring properties.
- (j) To ensure that street addresses comply with the *NSW Address Policy and User Manual 2021*.

Controls

- (a) Minimum lot sizes are contained in WLEP.
- (b) Where a proposed development involves the creation of a new lot, or number of new lots, capable of accommodating new buildings, the development application should be accompanied by at least a conceptual plan of the new building(s).
- (c) Applications must demonstrate that the following has been considered:
 - (i) Site topography and other natural and physical features;
 - (ii) Existing services and easements, or the need for new easements;
 - (iii) Vehicle access;
 - (iv) Any land dedications required (e.g. road widening);
 - (v) Existing vegetation;
 - (vi) Potential flood affectation and stormwater management requirements;
 - (vii) Existing buildings or structures; and

- (viii) Heritage Items, Conservation Areas and adjoining Heritage Items.
- (d) Any resulting lots must have characteristics similar to the prevailing subdivision pattern of lots fronting the same street, in terms of area, dimensions and orientation.
- (e) All resulting lots must have at least one frontage to the street, and adequate vehicle and pedestrian access.
- (f) Tree removal to permit vehicle access to a new subdivision is not supported.
- (g) Applications must demonstrate that any resulting allotments can facilitate development as per the zoning and controls on the land. This includes setbacks and open space provisions.
- (h) Subdivision or amalgamation must not result in the isolation of lots or reduce the development potential of adjoining land.
- (i) Applicants may be required to submit plans that clearly identify the future development potential of adjoining land to ensure its development potential will not be adversely impacted.
- (j) Subdivision or amalgamation must not compromise any significant features of the existing or adjoining sites including streetscape character, landscape features or trees.
- (k) Subdivision must not result in the creation of a new lot that contains significant site features that would render the land unable to be developed. For example the creation of allotments that are burdened by easements, flooding, or significant trees.
- (l) The isolation of parcels of land for the purpose of environmental protection only is not permitted. This land must be incorporated into any future development and maintained by the landowners.
- (m) Public lanes and public pedestrian passageways are not to be amalgamated with private land.
- (n) Where a rear lane is provided to adjoining land, the laneway configuration must be continued through any new allotments and existing access arrangements to adjoining land maintained.
- (o) Battle axe subdivision patterns will not be permitted within residential zones, unless it can be demonstrated that it is part of the prevailing subdivision pattern.
- (p) Battle axe subdivision patterns must result in one (1) or more allotments fronting the street and only one (1) allotment being serviced by an access handle.
- (q) Access corridors are to be located to ensure existing street trees are retained.
- (r) Access handles on battle axe blocks are to be a minimum of 3.5m in width and are to be landscaped in a manner complementary to the established character and streetscape of the area.
- (s) Where a proposed development will result in a change to, or introduction of a new street address, the proposed street addressing must be notated by the applicant on the DA and CC plans. This addressing must comply with the *NSW Address Policy and User Manual 2021*.

B13 EXCAVATION

Objectives

- (a) To set maximum acceptable extents of excavation which achieve the following objectives.
- (b) To minimise the impact of excavation on the natural environment, neighbouring properties, and streetscape.
- (c) To ensure the physical environment is preserved and enhanced through minimal site disturbance and the geotechnical stability of landfill and excavations.
- (d) To minimise cut and fill on sloping sites.
- (e) To encourage good quality internal environments including natural light and ventilation.
- (f) To prevent use of subterranean spaces as habitable rooms.
- (g) To prevent development exceeding the maximum car parking controls.
- (h) To ensure excavation does not adversely impact land stabilisation, ground water flows and vegetation.
- (i) To minimise structural risks to adjoining structures.

Controls

- (a) Excavation for basements will not be supported for dwelling house, attached dwelling, dual occupancy or semi-detached dwelling development, unless Council is satisfied that there is no alternative location on the site to accommodate parking and storage, the development satisfies the objectives of Part B13, and the basement:
 - (i) Has a maximum floor to ceiling height of 2.1m, except where the entry requires higher to meet Australian Standards,
 - (ii) Does not exceed one floor,
 - (iii) Will not contain any habitable rooms unless the room is at grade with external natural ground level along at least one side (refer to Figure 24), and
 - (iv) Has an area no greater than the area required to accommodate:
 - A maximum of 1 car parking space for dwellings with 1-2 bedrooms, or a maximum of 2 car parking spaces for dwellings with 3 or more bedrooms;
 - Waste storage for 3 x 140L bins per dwelling;
 - A plant room complying with control (b) of this part;
 - A maximum of 8 cubic metres of storage per dwelling; and
 - Minimum access requirements to the car parking and storage areas.
- (b) The maximum area permitted for a plant room in any development is the minimum required to meet Australian Standards, accommodate typical dimensions of equipment required and the associated circulation space to access the equipment for maintenance. DA plans should show the approximate location and size of equipment within the plant room.
- (c) Excavation should not add to the visual bulk and scale of the building.
- (d) Excavation should not result in the loss of naturally occurring sandstone. Where sandstone or natural rock are to be removed, opportunities for reuse on site should be considered (such as for front fencing or landscaping).

- (e) Avoid cutting into the natural stone wall of a street.
- (f) Avoid and minimise excavation where possible.
- (g) Minimise the inclination of any resulting sloping landscaping.
- (h) Existing natural features including trees and sandstone walls should be retained and incorporated as landscape features on the site in order to maintain the natural character of the landscape.
- (i) Step retaining walls in response to the natural landform to avoid creating monolithic structures, particularly where visible from the neighbouring dwellings and the public domain.
- (j) For sites with significant slopes a split-level building design is to be used to minimise excavation and backfilling.
- (k) Fill is not to be used to raise the ground level.
- (l) Excavation for garaging within sandstone walls facing the street must be minimised to preserve as much of the original wall as possible.
- (m) Development should accommodate stormwater detention tanks and storage systems within the excavated area.
- (n) Excavation is not permitted within 900mm of side boundaries and shall only occur within the building footprint, except where access to a basement car park is required.
- (o) Basement car parking is to be located fully below natural ground level. Where this cannot be achieved due to topographic constraints, a maximum protrusion above ground of 1.2m is permissible (refer to Figure 25).
- (p) Where excavation is proposed for development which is subject to Part C2 of this DCP, it is not to occur within a 1.5m setback from side boundaries and shall only occur within the building footprint except where access to a basement car park is required. Excavation will need to be setback greater where required to comply with Part C2, 2.3.2 Side and Rear Setbacks control (d).
- (q) All below-ground structures that are located below the groundwater table are to be fully tanked. These types of structures must not collect and dispose of subsoil/seepage to kerb and gutter.

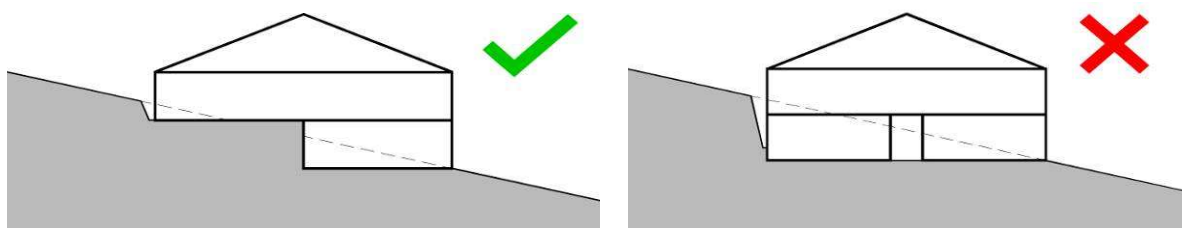

Figure 24 Habitable rooms are to have ample openings to an external wall for air and light.

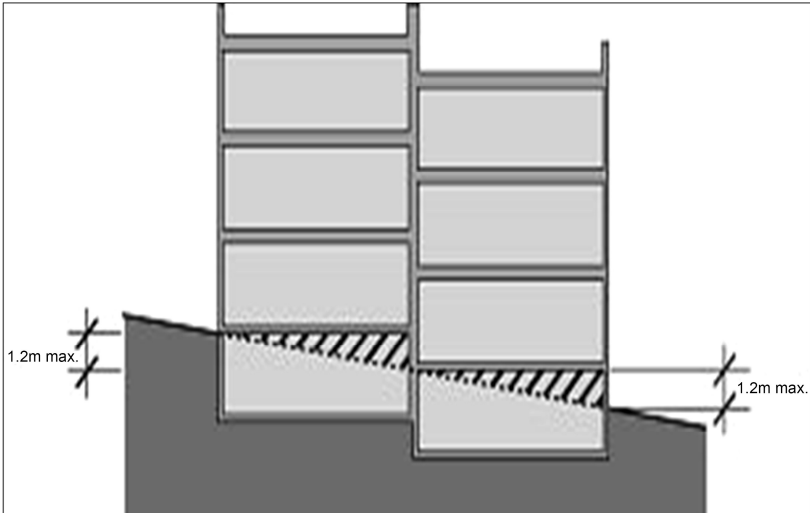

Figure 25 Basement parking level on sloping sites

B14 ADVERTISING AND SIGNAGE

This Part specifies objectives and requirements for the erection and display of advertising signs. The controls within this section should be read in conjunction with *State Environmental Planning Policy (Industry and Employment) 2021*, *State Environmental Planning Policy (Exempt and Complying Development Codes) 2008* (Codes SEPP) and WLEP, which define what can be carried out as exempt development and override these controls.

14.1 DESIGN AND LOCATION**Objectives**

- (a) To promote innovative, unique and creative signs that support retailers or businesses.
- (b) To deliver and maintain a high quality and cohesive public domain.
- (c) To maintain the architectural integrity of the subject building and adjacent buildings.
- (d) To ensure signage respects the architectural style of the building, contributes to the character of streetscape and is consistent with land uses.
- (e) To reduce energy consumption and minimise the negative amenity impacts of illuminated signs and advertisements.
- (f) To ensure the amenity of any adjacent non-commercial or residential uses.
- (g) To ensure the safety of pedestrians and traffic.
- (h) To ensure the harmony of signage with other features, having particular regard to the size and juxtaposition of other signs in the immediate vicinity.

Controls**14.1.1 General Controls**

- (a) Signage is to relate to the use of the building on which it appears and be designed to complement the established streetscape character, and not detract from significant views or vistas.
- (b) Signage is to be integrated into the architectural design of the building, awning or shop front (refer to Figure 28).
- (c) Where original sign panels have been incorporated into the parapet of the building facade, these should be used to identify the name or nature of the business only and not be used for advertising.
- (d) Signs should not obscure decorative forms or moulding and should observe a reasonable separation distance from the line of windows, doors, parapets, piers and the like.
- (e) The colour used in the design of a sign or structure should reflect the colour scheme of the building to which it will be attached.
- (f) Corporate colours should be limited to the advertising sign or structure.
- (g) Careful consideration should be given to the use of illuminated red, green and amber colours in proximity to signalised intersections.
- (h) Council may give consideration to temporary advertising in the form of bunting, banners, inflatable or canvas signs for special events provided that the temporary display period does not exceed four weeks.
- (i) Illuminated signage is to have no direct adverse impact on the amenity of residential properties.

- (j) Illumination of signs by floodlighting is preferable over the use of boxed fluorescent or neon lighting on buildings and places of architectural significance.
- (k) The use of neon tubing to highlight the features of a building is not permitted.
- (l) Flashing, moving or 3-D signs are not encouraged and will only be considered where permitted in this Part and after practical demonstration and a detailed assessment of any adverse impact on the amenity and character of the neighbouring area.
- (m) Signs are to be of a size and proportion that complement the scale of the existing façade, as well as surrounding buildings and signs.
- (n) Signage must not have a combined area in excess of 20m².
- (o) Shopping arcades are encouraged to erect a business directory at each entrance.
- (p) The following will not be permitted:
 - (i) Wall signs projecting more than 300mm from the wall.
 - (ii) Flashing or moving signs.
 - (iii) Advertising on display window piers or below the display window sill/kick plate.
 - (iv) Sky, roof, or fin signs.
 - (v) The display of bunting, banners, canvas, or fabric signs.
 - (vi) Inflatable signs and the like.
 - (vii) Advertising on garbage bins, telegraph posts, telephone booths, or other surfaces of a public nature.
 - (viii) Any sign which in Council's opinion, would adversely affect the operation of traffic lights, motorists or obstruct their vision.
 - (ix) Third party advertising.
 - (x) A-Board (sandwich boards).
 - (xi) Advertising on canvas shade blinds.
 - (xii) Signs that extend over street frontage boundaries, unless approved in conjunction with a shop which is built to the street alignment.



Figure 28 Types of signage

14.1.1 Third Party Advertising

- (a) Advertising on garbage bins, telegraph posts and other surfaces of a public nature is not permitted, except by prior contractual arrangement with Council.

- (b) Advertising signage on buildings and shop fronts must only relate to businesses operating within the same building or shop. Third party advertising is not permitted.
- (c) Where multiple occupancies exist within a single building or shop front, a coordinated scheme for all advertising and signage is required.
- (d) Council will not approve third party advertising. Signage must relate to the use of the building or land it is on.

14.1.2 Number of signs

- (a) Signage should not dominate the façade of buildings.
- (b) The number of signs per building or site will be assessed on the following:
 - (i) Number of existing signs;
 - (ii) Proportion of solid (wall surface area) to void (window and door openings) available for signage;
 - (iii) Length of frontage of the premises; and
 - (iv) Extent of facade detail and dimensional relief on the building which should not be obscured by signage.

14.2 SITE SPECIFIC CONTROLS**Objectives**

- (a) To ensure signage is compatible with the intensity of use in each land use zone and does not detrimentally affect the appearance of the site or adjoining land.
- (b) To ensure that signage complements the existing character of the area.

Controls**14.2.1 Residential Zones**

- (a) Any signage within a residential zone shall relate only to premises situated on the subject land and may specify any of the following:
 - (i) The purpose for which the land is used;
 - (ii) Identification and description of a person carrying on an occupation or business on the premises; and
 - (iii) Particulars of the goods or services dealt with on the premises.
- (b) Signs should be carefully designed to blend in with the established residential character.
- (c) Illuminated and electronic signs are not permitted.
- (d) A sign must not exceed 1m x 0.7m in size. The sign shall be affixed to the front façade of the dwelling or to the front boundary wall or fence.
- (e) In circumstances where there is no front fence, or where an existing fence does not have sufficient height to display a sign, and where the dwelling has a significant setback from the street front, Council will give consideration to the erection of a pole sign, having a height not greater than 2.8m.

14.2.2 Bondi Junction

- (a) Illuminated signage on buildings exceeding eight storeys is visible from the Harbour. Notwithstanding its regional significance, it is not intended that Bondi Junction compete with the established illuminated skylines of the City of Sydney or North Sydney. Any corporate advertising on the Bondi Junction skyline should only be for the purpose of serving the immediate region.

14.2.3 Campbell Parade

- (a) Projecting wall signs or flush wall signs above the awning of shops fronting Campbell Parade are not permitted with the exception of building identification signs.
- (b) Building identification signs shall be painted, identifying only the name of the building, and be traditionally located within the building parapet as a feature of the building.
- (c) Generally, neon signage is encouraged on window shop fronts and for under awning signs as an alternative to fluorescent illumination.

14.2.4 Wairoa Avenue in the vicinity of Wallis Parade

- (a) Neon signage may be permitted inside the window display area, provided it is not animated or flashing, due to the proximity of these shops to adjacent residential development.
- (b) No illumination or electronic signs above the awning will be permitted.

14.2.5 Neighbourhood shops

- (a) In areas located within *Part E3 Local Village Centres* or where shops or commercial premises exist in residential zones, such premises shall be restricted to the display of the following signs:
 - (i) One under awning sign;
 - (ii) An awning fascia sign;
 - (iii) Projecting wall sign;
 - (iv) Window signage; and
 - (v) One flush wall sign to each frontage or one top hamper sign having maximum dimensions 3m(W) x 1.5m(H).
- (b) Flush wall signs shall not be permitted on side walls facing adjoining residences (refer to Figure 29).
- (c) Animated, flashing signs and lights are not permissible.
- (d) Electrical conduits to illuminated signs are to be concealed or integrated into the relevant sign.
- (e) Shops shall consider the use of branded canvas shade blinds under the awning, in place of above awning advertising signs, as a means of retaining an appropriate neighbourhood scale. Such signage shall relate to the display of product logos and not involve the promotion of sales or specials. Signage shall occupy a maximum of 60% of the surface area of the blind and not involve fluorescent or iridescent paints.



Figure 29 Inappropriate location for flush wall signs

14.2.6 Mixed development buildings

- (a) Advertising signs and structures shall not be permitted above the awning on mixed development buildings unless they relate to activities conducted above ground floor level.

14.2.7 Development in excess of 15 metres in height

- (a) Naming rights to the building, often in favour of the principal tenant, shall be limited to the form of one advertising sign above the awning. The sign shall be designed and positioned in a manner sympathetic to the design criteria of the building. Where no principal tenant exists, a coordinated approach shall be used in meeting the signage needs of the tenants of a building. This should generally be limited to a directory panel in the common area of the building.
- (b) Roof signs shall not be permitted where they exceed the height of the building, or where they are flashing or moving. The assessment of any proposed roof sign shall include an evaluation of its impact on adjacent residential development, in terms of intensity and duration of illumination.

14.2.8 Automotive related activities

- (a) Freestanding pole signs shall have a maximum height of 6 metres above ground level, and the sign itself shall not exceed 3.4m² in area.
- (b) Pole signs shall not project more than 750mm beyond street alignment (refer to Figure 30).
- (c) A fin sign positioned as such shall have a maximum height of 1.5m above the roof structure (refer to Figure 30). No portion of the sign shall project over Council's footpath. Fin signs shall have a maximum area of 9m² referring only to the name of the establishment. Only one fin sign shall be permitted on the premises.

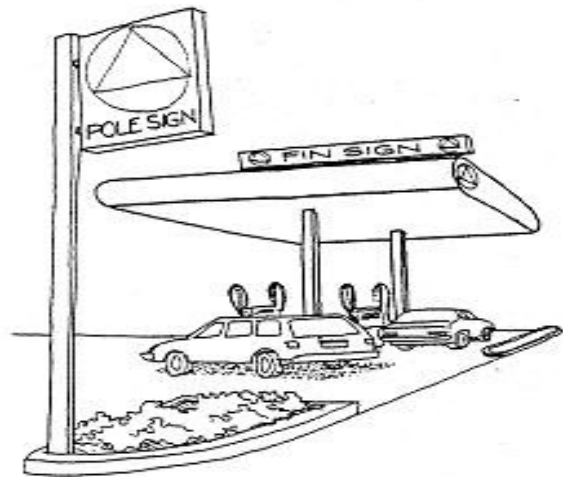

Figure 30 Example of pole and fin signs

14.2.9 Heritage Significant Buildings

- (a) Council will give consideration to architectural qualities of building when addressing the suitability of any proposed signs.
- (b) Signs must not conceal or obscure architectural features.
- (c) Generally, on shop fronts signage will be restricted to suspended under awning signs and awning fascia signs.
- (d) Signage above the awnings must be limited to appropriate areas allocated for such a purpose in the original facade design (parapets, for example), and must not extend above the parapet.
- (e) Flashing, electronic, illuminated or animated signs will not be permitted.
- (f) Council encourages restoration of original painted signs, and construction of new signs using traditional designs.
- (g) In the absence of any shop front awnings, signage shall be kept below the height of awnings on adjacent buildings. In such circumstances, projecting wall signs should take the form of lantern signs, where appropriate.

14.3 SIGN SPECIFIC CONTROLS**Objectives**

- (a) To ensure that proposed signage is compatible the buildings and surrounding character of the area.

Controls**15.4.1 Under-awning signs**

- (a) Under awning signs must:
 - (i) Have a minimum clearance of 2.6m above the footpath and be centrally positioned under the awning;
 - (ii) Not exceed 1.8m(W) x 300mm(H);
 - (iii) Be setback 600mm from the footpath edge;
 - (iv) Not project beyond the width of the awning; and
 - (v) Be separated from other under awning signs by 3m where practicable.

14.3.2 Projecting Wall Signs

- (a) Where permitted projecting wall signs shall:
 - (i) Extend a maximum projection of 750mm from the face of the wall (refer to Figure 31);
 - (ii) Have a minimum clearance of 2.6m above the footpath;
 - (iii) Not extend above parapet height;
 - (iv) Align with signs on adjacent buildings; and
 - (v) The vertical dimension of the sign shall be equal to or greater than the horizontal dimension.
- (b) Council will consider variations to the maximum projection requirement only where, in Council's opinion, the requirement for a sign of vertical proportion does not suit the style and character of the building, or details and proportions of the façade. In these instances square or circular signs may be considered, having a maximum projection of 1.5m from the facade. In such circumstances, buildings 3 storeys or greater are considered more appropriate to scale and proportion of such signs (refer to Figure 33).
- (c) Signs are to be attached to undecorated wall areas. Where projecting wall signs of vertical proportion are proposed, vertical engaged piers present on the facade of older buildings should be used.

14.3.3 Awning fascia signs

- (a) Fascia signs are to be flush with the awning and not illuminated.
- (b) They shall not project above or below the awning fascia.
- (c) Sign writing shall be limited to the street number, name and general nature of the business.
- (d) Product identification on an awning fascia shall not be permitted.
- (e) Where a building comprises a number of tenants, such as in an arcade, the awning fascia should identify the name of the arcade only.

14.3.4 Flush Façade Panels

- (a) Signs are to be attached to undecorated wall areas.
- (b) Façade panels should align with windows or doors or be centered on parapets (refer to Figure 32).
- (c) Opportunities may exist for flush wall signs on the blank side or rear walls of some buildings, provided that:
 - (i) The commodities or services advertised are sold within the premises to which the sign is affixed or painted;
 - (ii) The total area of signage is no greater than 4.5m²; and
 - (iii) The number of such signs is limited to one only.

14.3.5 Top hamper signs

- (a) Top hamper signs:
 - (i) May project up to 150mm from the building façade;
 - (ii) Must have a minimum clearance of 2130mm above ground level;
 - (iii) Shall have dimensions proportionate to the size of the top hamper fascia;
 - (iv) Shall not exceed 600mm in height, with a maximum length of 4000mm;
 - (v) Shall be restricted to one sign per premises, unless the Council considers the buildings frontage sufficient to accommodate more than one such sign;
 - (vi) Should not extend below the level of the head or doorway or window to which they are attached;
 - (vii) Should allow a proportion of the wall surface area of the top hamper to be exposed; and
 - (viii) Shall be set back 600mm from side boundaries to satisfy fire regulations.
- (b) Signs are to be within the perimeter of the building walls.
- (c) Illumination is permitted.

14.3.6 Building Identification Sign

- (a) Building identification signs are to be located at building parapet height, for the purpose of identifying the building.
- (b) They will be permitted where, in Council's opinion, there is sufficient wall surface area to display the sign, and where the sign is proportionate to the façade area, and appropriate to the design and decoration of the building.
- (c) Where the building comprises a number of tenants, only one identification sign will be permitted where that tenant occupies floor space above awning level.
- (d) Building identification signs should be positioned at the local point of the building façade, generally central to the top parapet, and shall not project by more than 300mm from the wall.
- (e) Building identification signs shall be integrated with the character and form of the building and not alter its roofline.

14.3.7 Murals

- (a) Council may consider the use of a mural as signage for the purposes of building identification and advertisement.

- (b) A mural is to be sensitive to the character and amenity of the area.
- (c) A mural must not be located on a heritage item or contributory building, or detract from the significance of a heritage conservation area.
- (d) Any corporate branding, logos, markings or similar are not to occupy more than 5% of the total mural area.
- (e) No third party advertisements are to feature in a mural.
- (f) If the mural contains no advertising material and does not act as signage, it may be considered as public art. If the mural is public art, it does not require development approval and is to be carried out in accordance with the *Waverley Public Art in the Private Domain Guidelines*.

14.3.8 Window signs

- (a) Painted signs on shop front windows, particularly those using fluorescent and iridescent paints, shall be temporary in nature, and not cover more than 60% of the window surface area (refer to Figure 34).
- (b) Painted window signage which is skeletal in form, identifying only the business name of the premises, may be permanently applied to the window surface.

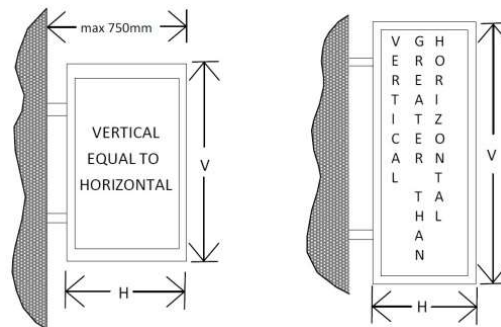

Figure 31 Dimensions for vertical projecting wall signs

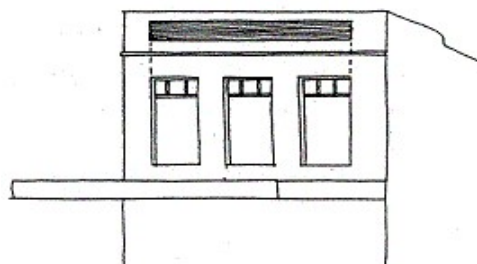

Figure 32 Preferred alignment of façade panels

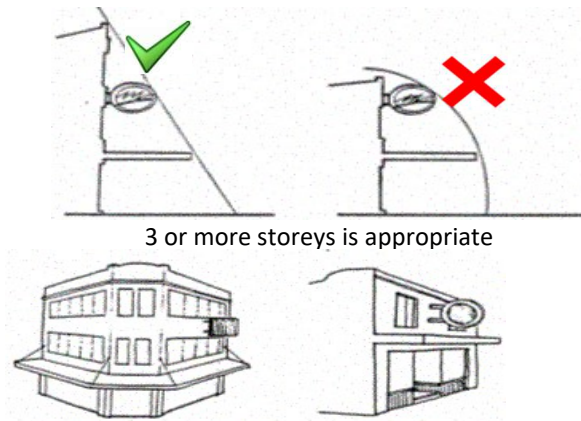

Figure 33 Signage for buildings with 3 or more storeys

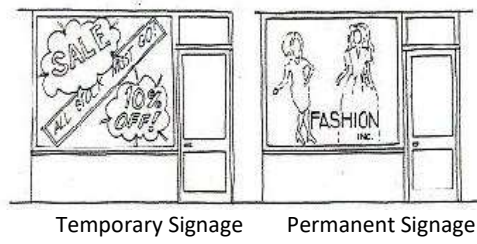

Figure 34 Painted shop front window sign

B15 PUBLIC DOMAIN

The public domain is Waverley’s shared space for residents and visitors alike. It is important that development that addresses the public domain is attractive, safe and accessible. The public domain should be characterised by accessibility, excellence in design, high quality materials and well-integrated public art.

This Part is to be read in conjunction with Council’s Street Design Manual and Public Domain Technical Manual which provide further details on the application of the controls outlined in this Part.

15.1 IMPROVING THE PUBLIC DOMAIN

Objective

- (a) To ensure that the public domain receives adequate solar access.
- (b) To protect significant views and vistas from the public domain.
- (c) To ensure that development contributes to the activity, safety, amenity and quality of the public domain.
- (d) To ensure that development adjoining the public domain is of a high quality.
- (e) To provide legible and accessible development.
- (f) To reinforce the character of the area.
- (g) To minimise the use of, and ameliorate the effect of, blank walls at ground level.
- (h) To minimise risks to the community of natural or environmental hazards, including urban heat islands or localised flooding.
- (i) To maximise the accessibility and security of public open space.

To improve nighttime movement and activation of street frontages.

Controls

- (a) Overshadowing effects of new buildings on publicly accessible open space is to be minimised between 9am – 3pm on 21 June.
- (b) Development is not to impede important or significant views from the public domain to public places, parks, Sydney Harbour or the eastern coastline, heritage buildings, monuments, or public artworks.
- (c) Development is to identify and improve key view corridors from the public domain.
- (d) Buildings are to be designed to frame important views from the public domain and within large sites.
- (e) Low level views of the sky along streets and from parks are to be maintained.
- (f) Buildings are to be designed to address the street and to utilise high quality finishes and public art to enhance the public domain and pedestrian interface.
- (g) Blank walls are not supported within centres. Where blank walls must be provided, utilise artworks or interesting façade designs to enrich the public domain.
- (h) Ground entry lobbies and commercial tenancies are to have entries at the same level as the adjacent footpath or public domain.

- (i) The ground floor of developments is to be designed so that there are regular opportunities for direct surveillance of the adjacent street or public domain.
- (j) Car parking areas at ground level must be screened by active uses to a minimum depth of 6m from the façade visible to the street or public domain.
- (k) Align setbacks between buildings with lanes and pedestrian links to enable clear lines of sight.
- (l) Ensure development manages and mitigates environmental or natural hazards, and does not exacerbate risks to existing developments or the public domain.
- (m) New residential flat building and shop top housing development may be required to provide street lighting to contribute to nighttime public safety.
- (n) Development involving the construction of a new residential flat building or shop top housing development are required to locate utility connections underground.
- (o) New residential flat building and shop top housing development will be required to provide footpath paving upgrades in accordance with the *Waverley Public Domain Technical Manual*.

15.2 ACTIVE STREET FRONTAGES

This Part applies to commercial and mixed use development that is subject to *Part E Site Specific Development* and/or that is marked on the WLEP Active Street Frontages Map

Active frontages include internal building spaces that have direct pedestrian access or visibility to the street and provide important centre activities such as commercial, civic and entertainment uses. These frontages contribute to the liveliness of a street, and are a key component of a people focused place.

Uses that can facilitate active frontages are any of the following:

- Entrance to retail;
- Shop front;
- Glazed entries to commercial and residential lobbies occupying less than 50% of the street frontage, to a maximum of 12m frontage;
- Café or restaurant if accompanied by an entry from the street;
- Active office uses, such as reception, if visible from the street; or
- Public building if accompanied by an entry.

Objectives

- (a) To promote pedestrian activity and safety in the public domain
- (b) To provide a high degree of surveillance over the street.
- (c) To provide transparency and visual connection between the street and the building's interior.
- (d) To facilitate future adaptability and flexibility of uses.
- (e) To provide high standards of accessibility.
- (f) To supplement the WLEP controls for active street frontage.
- (g) To maximise the amount of active frontages throughout centres.
- (h) To ensure development encourages appropriate streetscape activation and active participation by the public.
- (i) To ensure that development provides a well-connected, weather protected public domain to reduce the impact of wind and rain and provide adequate shade for pedestrians.
- (j) To create a 'public face' for buildings to enhance the character of streets.
- (k) To promote a high level of visual connectivity and physical accessibility between the street and the active frontage premises.

Controls

15.2.1 General Controls

- (a) Development is to be constructed to the front property boundary.
- (b) Active ground floor uses are to be at the same general level as the footpath and be accessible directly from the street.
- (c) Sites identified as Active Street Frontage in this DCP must not provide vehicle access across the Active Street Frontage.
- (d) At ground level provide large, clear glazed windows with the sill at a minimum of 500mm above finished floor level.

- (e) Opaque or obscured glazing is not acceptable.
- (f) Reinforce corner frontages on primary shopping streets with shop or office front windows.
- (g) Openable shop fronts for restaurants or cafes and the like are encouraged, to a maximum of 80% of the façade.
- (h) Outdoor restaurants, cafes and the like are encouraged.
- (i) First level active frontages are encouraged. Some centres require first level active frontages, refer to *Part E Site Specific Development*.
- (j) Commercial ground floor frontages are to provide clear glazing where ever possible to promote passive surveillance and contribute to street activity.
- (k) One entrance to civic, entertainment, community, commercial or retail uses per 6m-10m of street frontage must be provided.
- (l) Provide regular tenancy widths, preferably between 6m-10m, or similar to adjacent shopfronts.
- (m) Development is to utilise a 500mm depth to articulate the building façade at ground level to create interest and variety in the streetscape. Ground level walls should be experienced as having depth and providing a transition between inside and outside. Modulation of the façade may include openings, setbacks, windows and doors, columns and structure.
- (n) Where carpark entrances must be located within an active frontage, innovative design solutions are to be provided that create an engaging or attractive entrance.
- (o) Where possible direct ramps and stairways into the depth of the tenancy instead of along a frontage, or provide access from a secondary frontage.
- (p) A variety of high-quality materials is to be used for active street frontages, with detailing that is of a human scale.
- (q) Active uses on levels that are setback are encouraged to look over the street, particularly on corner sites.
- (r) The context analysis submitted with the application is to determine whether the active frontage is in an area of predominantly traditional or contemporary shopfronts, and whether the frontage is on a primary or secondary shopping street. The design of the frontage is to comply with the relevant controls below. Refer also to any site specific controls in *Part E Site Specific Development*.

15.2.2 Shopfront Style

- (a) Development that is of a Traditional Shopfront style is to:
 - (i) Interpret and represent the design of adjacent Traditional Shopfronts.
 - (ii) Retain or rebuild any existing shopfronts, using construction techniques and materials that respect the original style, period and architecture of the building.
 - (iii) Provide between 40-80% of the ground level façade as glazing.
 - (iv) Articulate entrances in a similar manner to surrounding Traditional Shopfronts.
- (b) Development that is of a Contemporary Shopfront style is to:
 - (i) Have a high degree of articulation and diverse materiality.
 - (ii) Articulate entrances with inset doorways and thresholds.
 - (iii) Provide between 40-80% of the ground level façade as glazing.

15.2.3 Primary Shopping Street Frontages

- (a) Active frontages are to occur at ground level along all primary shopping streets.
- (b) Not more than 10% of the street frontage on a lot is to have blank walls or service areas (excluding structure, columns and beams).
- (c) On sites with wider frontages (over 10m) at least 85% of the building frontage is to be associated with retail uses such as entries, display area, café, restaurant and shop floor.
- (d) On sites with narrow frontages (under 10m) at least 70% of the building frontage is to be associated with retail uses such as entries, display area, café, restaurant and shop floor.

15.2.4 Secondary Shopping Street Frontages

- (a) At least 50% of the frontage is to be active frontage.
- (b) Not more than 15% of the street frontage can have blank walls or service areas (excluding structure, columns and beams).
- (c) No less than 80% of the building is to be aligned to the street.
- (d) Active uses on levels that are setback are encouraged to have active uses looking over the street, particularly on corner sites.

15.3 ARCADES AND THROUGH SITE LINKS

Objectives

- (a) To develop a comprehensive, compact, easy to follow, safe and accessible pedestrian network.
- (b) To increase permeability of large sites and within centres.
- (c) To ensure that arcades are safe and accessible.
- (d) To expand and enhance the public domain.
- (e) To promote pedestrian activity throughout centres.
- (f) To increase active street frontages throughout centres.
- (g) To provide continuity of retail throughout centres.

Controls

- (a) Potential street-to-street connections involving sites in separate ownership should consider liaising to develop compatible proposals and submitting concurrent applications to create new through site links.
- (b) Arcades and through site links must:
 - (i) Connect to a public street on both ends;
 - (ii) Be well lit and designed to minimise opportunities for loitering;
 - (iii) Incorporate high quality floor finishes;
 - (iv) Be in a straight alignment, bends or dog legs are not allowed;
 - (v) Have visual connection from street to street;
 - (vi) Provide an accessible path of travel from street to street;
 - (vii) Have a minimum width of 3m clear of all obstructions;
 - (viii) Be either open to the sky or with a glazed roof;
 - (ix) Be open for public use for at least between the hours of 7:00am and 10:00pm daily; and
 - (x) Have signage indicating public accessibility and the street to which the lane connects.

*Refer to Figure 35 for a good example of a retail arcade with active frontages.
- (c) If a through site link is to be closed between 10:00pm and 7:00am via a gate or other mechanism, the gate must be latched into the 'open' position between 7:00am and 10:00pm, to allow an accessible path of travel.
- (d) Developments with public spaces such as arcades and through site links are to incorporate public art within the development (refer to *Part B11 Public Art*).
- (e) Arcades or through site links within any of the centres identified in *Part E Site Specific Development* must:
 - (i) Provide active frontages at the ground level, and in some cases first level, in accordance with *Section 16.2 Active Street Frontages*;
 - (ii) Maximise entries and display windows to shops and/or food and drink premises to increase pedestrian interest and interaction;
 - (iii) Provide elements of visual interest;
 - (iv) Provide predominantly retail, entertainment, civic or commercial uses;
 - (v) Provide a maximum of 15% of the frontage as the entry to a residential premise;
 - (vi) Provide one door per 4m; and
 - (vii) Provide not more than 10% of the frontage as blank walls or service areas (excluding structure, columns and beams).

- (viii) Adhere to Council's health policy by regular deep cleansing of the pedestrian access through the arcade.

15.4 AWNINGS AND COLONNADES

Objectives

- (a) To increase the usability and amenity of public footpaths by protecting pedestrians from rain, strong winds, summer sunlight and glare.
- (b) To encourage pedestrian activity along streets to support and enhance the vitality of the local area.
- (c) To contribute to the character of the streetscape.
- (d) To ensure that heritage significance is taken into consideration in the application for awnings.

Controls

- (a) Colonnades are not permitted in areas with active frontages.
- (b) Awnings are to be provided above all active frontages.
- (c) Continue the height, depth and form of existing awnings where they occur in the street.
- (d) Awnings are to provide a consistent height above the footpath with a minimum height between the footpath level and underside of awning of 3.1m.
- (e) Awnings should extend across the width of the footpath to within 0.6m of the kerb line.
- (f) Awning height is to be in the range 3.2m - 4.2m, with the final height determined to ensure continuity in appearance and weather protection with adjoining awnings.
- (g) Box awnings with slim fascias are to be provided.
- (h) Preferred awning depth is 3m.
- (i) Awnings are required to step with topography. Sloping awnings are discouraged.
- (j) Building entries must be covered.
- (k) The colour of awning fascias is to be consistent along the street.
- (l) Where street trees are required the entire length of the awning is to be set back from the kerb by 1.2m. Cut outs for trees and light poles in awnings are not acceptable.
- (m) To control sun access/protection, canvas blinds along the street edge may be permitted, subject to design merit and assessment.
- (n) Signage on blinds is not permitted.
- (o) Provide appropriate under awning lighting to facilitate night use and public safety.

15.5 REFLECTIVITY

Objectives

- (a) To mitigate adverse glare from reflective surfaces on street level.
- (b) To ensure reflectivity does not impact upon the function of the public domain.
- (c) To minimise adverse solar reflection through the reduction of reflective materials and the use of shading devices.
- (d) To avoid façade treatments containing large areas of glazing.
- (e) To minimise potential impact on pedestrians and occupants of neighbouring buildings.

Controls

- (a) Limit the use of large areas of glass in facades to a maximum of 60% of the façade surface area above ground level.
- (b) Shade glass areas with shading devices appropriate to the orientation. East and west-oriented glazing benefits from vertical shading devices, whilst north benefits more from horizontal shading devices.
- (c) Reflected solar glare on drivers should not exceed 500 candelas/m². A candela is the base unit for measuring the intensity of luminance under the International System of Units (SI).
- (d) Mirrored glass and other highly reflective materials should not be used on building exteriors.
- (e) All panels and elements on vertical façades are to have a maximum specular reflectivity of visible light from normal angles of incidence of 20%.
- (f) Any surface inclined by more than 20 degrees to the vertical (inclined glass awnings or cladding on inclined roofs) are to have a maximum specular reflectivity of visible light from normal angles of incidence of 10%.
- (g) The above mentioned limits may need to be further reduced depending on the outcome of the analysis by a reflectivity consultant of the impact on drivers' visibility. Refer to the *Waverley Development Application Guide* for information about when a reflectivity report is required.

15.6 SHOPFRONT SECURITY

Objectives

- (a) To improve the amenity of the public domain by discouraging roller shutters.
- (b) To promote engagement with shops and businesses after operating hours through window displays.
- (c) To prevent vandalism of shop fronts.

Controls

- (a) Roller shutters on shop fronts are not permitted.
- (b) Applications involving a change of use of retail premises shall be required to retain or reinstate the window shop front.
- (c) Where the nature of the proposed retail activity does not warrant a window shop front display, consideration may be given to folding or sliding glass doors.
- (d) Security grilles on shop fronts are discouraged.
- (e) Where security grilles are to be provided, they may only be fitted internally behind the shopfront and are to be fully retractable and at least 50% transparent when closed.

15.7 MINOR ENCROACHMENTS

This section applies to the following structures that are permitted to encroach from private property onto public property:

- Awnings;
- Balconies;
- Shutters;
- Building signs;
- Decorative structures;
- Private security lighting;
- CCTV cameras; and
- Special drainage structures.

Objectives

- (a) To ensure encroachments from private property onto public property are safe for pedestrians and vehicular traffic.
- (b) To ensure encroachments conserve the characteristics of an area.
- (c) To ensure that minor encroachments do not result in any loss of public amenity or safety and do not compromise future plans for road realignment or footpaths and stormwater drainage.
- (d) To allow architectural features that enhance the appearance of the building and streetscape.
- (e) To preserve and restore buildings which are a heritage item or located within a heritage conservation area

Controls

15.7.1 General

- (a) Encroachments are to be of a minor nature.
- (b) Encroachments must not pose a hazard, particularly to pedestrians or other users of public space.
- (c) Encroachments must be consistent with the character of the surrounding area.
- (d) Encroachments must:
 - (i) Be a maximum of 300mm;
 - (ii) Not interrupt pedestrian movement or public space or amenity;
 - (iii) Not enter into public space between ground/footpath level and 1m above ground/footpath level;
 - (iv) Not reduce the width of a footpath to less than 1.8 metres wide;
 - (v) Not extend over a vehicular carriageway; and
 - (vi) Must have a minimum setback of 600mm from the kerb face.

B16 INTER-WAR BUILDINGS

This Part applies to Interwar buildings and is to be read in conjunction with the *Waverley Inter-War Building Design Guidelines*.

Definition:

An Inter-War building is a building constructed in the period from c.1914 to c.1940, typically containing three or more residences. Buildings built between 1940 and 1950 with identifiable Inter-War characteristics are also considered to be Inter-War buildings.

Objectives

- (a) To achieve the provisions of the *Waverley Inter-War Building Design Guidelines* as prepared by Council.
- (b) Encourage retention and appropriate conservation works including repair and maintenance of these buildings and their significant elements.
- (c) Encourage the removal of inappropriate alterations and additions and the reinstatement of original missing details and building elements.
- (d) Enhance the character of the streetscape and the broader Waverley Local Government Area.
- (e) Retain and enhance the landscape setting.
- (f) Facilitate design excellence and innovative approaches to alterations and additions in a way that enhances the essential characteristics of both the building and the streetscape without dominating the original building.
- (g) Facilitate upgrades in line with Australian Standards, the Building Code of Australia and other standard and codes whilst maintaining the character and significance of buildings.

Controls

16.1.1 General

- (a) All Inter-War Buildings should comply with Part B16 Inter War Buildings. Inter-War Buildings that are Heritage Items or located within a Heritage Conservation Area must also comply with the provisions of *Part B9 Heritage*.
2. With reference to the *Waverley Inter-War Building Design Guidelines*, the SEE and plans demonstrate the following:
 - (i) Locate the Inter War building and note if they are heritage items, located in a Heritage Conservation Area;
 - (ii) Identify the context of the street;
 - (iii) Identify the style of the building and the key defining features;
 - (iv) Identify the type of building;
 - (v) Determine the proposed level of modification;
 - (vi) Assess the proposal against the compliance check list;
 - (vii) Complete the compliance table.
- (c) Retain and maintain original building fabric and decorative elements such as parapets.

- (d) Provide maintenance and repairs where necessary utilising traditional techniques and materials.
- (e) Encourage the retention and maintenance of original decorative materials and finishes including fencing and light fixtures
- (f) Maintain and retain original face brickwork and stonework.
- (g) Preserve the building’s contribution to, and relationship with, the streetscape.
- (h) Alterations and additions are to be complementary and secondary to the existing building design.
- (i) Subtly differentiate new additions and alterations from the original building.
- (j) Minimise the visibility of new additions from the public domain and ensure that the original building remains dominant.
- (k) Demonstrate a high standard of design excellence.
- (l) Upgrade the systems within the building in line with the BCA, AS, DDA and other standards and codes as necessary; and
- (m) Maintain the integrity of the design of the building when providing upgrades to the building.
- (n) Development is required to apply a material or colour scheme in accordance with the *Waverley Inter-War Flat Building Heritage Design Guidelines*.
- (o) Any on-site car parking is to maintain the building’s relationship to the streetscape.
- (p) Comply with the conservation principles in Table 9.
- (q) Despite controls above, strict compliance with Table 9 may be varied if Council is satisfied that a proposal for alterations and additions can demonstrate innovation, design excellence and consistency with the objectives of this Part.

Building Element	Conservation Principles
Form and Massing	Explore the retention of simple prismatic masonry forms, simple hipped roof forms and respond to the character of the building
	Retain the principal form of the buildings.
Streetscape Elevation(s)	Retain the principal streetscape elevation(s).
Roof Finishes	Retain terracotta tile finishes or replace to match.
	Replace flat roofs as necessary.
Roof Parapet	Retain parapets and do not extend and reinstate where previously removed.
Wall Finishes	Retain decorative brickwork and do not paint or render face brickwork.
	Paint non original finishes in dark neutral tones to suggest face brickwork.
	Retain original textured render finishes (smooth, fan trowelled, roughcast).
	Retain original shingle finishes and original battened sheet finishes including projecting window bays.
Signage	Retain building name on façade or reinstate building name based on evidence.
Verandah	Retain original openings and do not infill original verandahs except in noisy locations where highly sympathetic additions may be appropriate.

	Explore opening up of previous infilled verandah or replace glazing with frameless glazing.
	Retain the pattern and proportion of original windows and timber or steel finish.
	Replacements need to match the original proportion and finish.
	Retain proportion and glazing pattern of windows converted to doors.
	Remove external security bars and provide alternate security sympathetic to the style
Fenestration	Retain the pattern and proportion of original windows and timber or steel finish.
	Replacements need to match the original proportion and finish.
	Retain proportion and glazing pattern of windows converted to doors.
	Remove external security bars and provide alternate security.
Entry	Retain original timber French doors with multi pane glazing.
	Retain / restore porch.
	Retain original steps and simple pipe rail handrail.
	Retain terrazzo flooring, unglazed terracotta tiles, original concrete slab awnings and wall finishes
	Fire and safety and security upgrade discreet and retain original fabric.
Stylistic Features	Retain stylistic features listed in Style table (refer to <i>Waverley Inter-War Building Design Guidelines</i>) and reinstate lost features.
Additions	Minor additions should retain the overall form and character of the building.
	Minor additions should not be visually prominent from the street.
Attic Conversion – storage and habitable	Use of space in the roof form may be acceptable, with consideration of WLEP building height and floor space ratio development standards
	Control size and location of skylights and retain gable end finishes.
	Fenestration should respond to the scale and proportion of the existing fenestration.
Inset Balcony	Avoid inset balconies to visible roof planes.
Dormers	Front dormers are not acceptable.
	Rear dormers may be acceptable as they (are not visible from the street) have limited visibility.
	Side dormers should be proportional in scale with the existing roof, and may be acceptable depending on visual impact and impact on views.
Roof Additions	Roof additions are generally only supported where established surrounding streetscape scale is higher.
	Retain parapet and set back additions behind parapet to ensure skyline is retained.
	Use recessive finish detail and colour to minimise impact of additions.
	Minimise the thickness of the roof edge.

	Setback privacy screens and dividing walls from parapet (planter solution) to ensure skyline is not interrupted.
Balconies	Balcony additions to rear only.
	Balcony should support stylistic characteristics and articulation of façade.
Undercroft Alterations	Re-use of laundries and undercroft areas is acceptable.
Rear Additions	Set down additions to the rear below the gutter height.
Fences and Gates	Retain original low masonry boundary fences and retain original materials.
	Do not raise height of fence. Use landscape to limit access and provide privacy.
Landscape	Retain landscape areas forward of building line and maximise landscape to street front.
	Use landscape to conceal mailboxes, bins and new ancillary facilities.
	Landscape – retain ‘crazy’ flagstone, fountains, approach paths and other hard landscaping features.
Parking	Retain original basement garage opening widths.
	Do not widen driveways and retain concrete wheel strips.
	Do not construct garages or carports in front setback or in front of buildings
	Pergolas may be appropriate to mitigate broad expanse of car stands.
	Recess garage doors.
Mailboxes	Retain original inset mailboxes built into fence.
	Expand in similar style as necessary or locate new mailboxes within landscape.
Interior	Modification of the interior can occur if there is no impact on the street facades.
Upgrades	Fire security upgrades must be discreet and respect original fabric.
	The character of the street presentation and foyer need to be retained as far as practical when implementing upgrades.
	Alternate solutions should be explored to allow the retention of the original fabric.

Table 9: Inter-War Building Conservation Principles

16.2 Shopfronts

- (a) Retain the original significant features including ingoes, signage, glazing pattern, location of doors, tiling and awnings.
- (b) Respect the original form, scale and detailing of the building and not compromise the integrity and consistency of the streetscape.
- (c) Aim to increase accessibility to the shopfront through permanent or temporary measures as deemed suitable in consultation with Council.

B17 SOCIAL IMPACT ASSESSMENT

The *Waverley Social Impact Assessment Guidelines 2022* seek to highlight the importance of and guide the assessment of social impacts of proposed development. Applicants of all Development Applications should refer to the Guidelines to understand what Social Impact Assessment is and whether a Social Impact Statement is required for application lodgement.

Objectives

- (a) To encourage positive social impacts and mitigate negative social impacts, and increase the validity and reliability of the Social Impact Assessment,
- (b) To maximise community benefits and encourage appropriate behaviours.
- (c) To reduce cumulative impact of development and ensure diversity in housing.
- (d) To ensure that the local community has input into the Social Impact Assessment.
- (e) To reduce interaction between children/students/sensitive beliefs and restricted premises/sex service patrons.
- (f) To increase access to public open space.
- (g) To identify preferred community consultation methods and key planning matters early.

Controls

- (a) A Social Impact Statement (SIS) should be prepared if the proposed development is one of the following:
 - Loss of low-rental dwellings (see State Environmental Planning Policy Housing 2021 for definition)
 - Strata subdivision of 4 or more lots
 - \$10,000,000 or greater construction cost
 - Gross Floor Area of 3,000sqm or greater (see Waverley Local Environmental Plan for definition)
 - Reduction in dwelling numbers on site
 Council officers may request a SIS for development not included within the Guidelines at their discretion.
- (b) Plan of Management documents prepared as required by the Waverley Development Application Guide should be robust and adhered to.
- (c) Co-living development with the capacity to accommodate **20 or more lodgers** must have a full-time on-site manager accommodated within the premises.
- (d) Applicants must prepare a locality plan identifying the number and size of the same development type/land use within a **3km** radius, and justify how the addition of a development requiring an SIA will not produce an adverse cumulative impact given the context. This applies to the following development types:
 - Boarding house accommodation
 - Co-living housing development
 - Backpacker's accommodation
 - Pubs/registered clubs

ANNEXURES

Annexure B1-1
Examples of Building Material Reuse

Material	Reuse/recycling potential
Concrete	Reused for filling, levelling or road base
Bricks and Pavers	Can be cleaned for reuse or rendered over or crushed for use in landscaping and driveways
Roof Tiles	Can be cleaned and reused or crushed for use in landscaping and driveways
Untreated Timber	Reused as floorboards, fencing, furniture, mulched or sent to second hand timber suppliers
Treated Timber	Reused as formwork, bridging, blocking and propping, or sent to second hand timber suppliers
Doors, Windows, Fittings	Sent to second hand suppliers
Glass	Reused as glazing or aggregate for concrete production
Metals (fittings, appliances and wiring)	Removal for recycling
Synthetic Rubber (carpet underlay)	Reprocessed for use in safety devices and speed humps
Significant Trees	Relocated either onsite or offsite
Overburden	Power screened and used as topsoil
Garden Waste	Mulched, composted
Carpet	Can be sent to recyclers or reused in landscaping
Plasterboard	Removal for recycling, return to supplier

Note: More information is available at the following link: <http://www.epa.nsw.gov.au/warr/index.htm>

Annexure B1-2 Waste and Recycling Generation Rates

This section provides waste and recycling generation rates for different types of developments. In cases where a mixed-use development is proposed, developments should use each sections generation rates for the residential and commercial components of the building.

Residential Generation Rates

Waste generation rates apply to all types of residential development unless specifically listed in the tables below (for example boarding houses).

A NSW State Government mandate applies from 1 July 2030 requiring local government to collect organic materials (food and garden waste) from residential premises. Waste generation rates in this section are structured in a way to future proof new development and to facilitate this mandate in relation to current (Non-FOGO) and future (FOGO) waste generation rates.

New development must demonstrate that they can provide for adequate storage waste capacity, based on the specified waste generation rates for current and future services, as outlined below

Non-FOGO generation Rates				
Dwelling type	General Waste (L/week)	Container Recycling (L/week)	Paper and cardboard Recycling (L/week)	Garden Organics Recycling (L/week)
Single Unit Dwelling (House)	120	60	60	60
All units	120	60	60	10

FOGO generation rates				
Dwelling type	General Waste (L/week)	Container Recycling (L/week)	Paper and cardboard Recycling (L/week)	Organics (Food and Garden) Recycling (L/week)
Single Unit Dwelling (House)	120	60	60	120
All units	120	60	60	60

The following types of land uses are considered residential under the *Local Government Act 1993*: Boarding houses/Time shares, Serviced apartments and as such require a domestic waste service, incurring a Domestic Waste Charge. Co-living housing is also considered residential. Appropriate waste generation rates are provided below for a number of these types of land uses.

Generation Rates				
Dwelling type	General waste L/unit/week	Container Recycling L/unit/week	Paper and cardboard recycling L/unit/week	Organics (Food and Garden) Recycling (L/week)
Boarding House/co-living housing/ Time Share studios with kitchen	60/apartment	30/apartment	30/apartment	20/apartment
Boarding House/co-living housing/ Time Share studios without kitchen	50/apartment	20/apartment	20/apartment	15/apartment
Serviced Apartments	35/apartment	20/apartment	20/apartment	

Use the figures above to quantify the total waste and recycling over a fortnight. This will assist you to calculate the number of bins and hence the storage space required.

Commercial Generation Rates

Waste generation rates for commercial development are to be calculated using the rates below. Floor space includes patron usage area such as seating (indoor and outdoor). To ensure building flexibility for future uses, Council may require a higher generation rate than the proposed use. Where type of premises is not listed, consideration will be given on a case by case basis.

A NSW Government Mandate applies that businesses must provide for an organics collection service over a phased timeline up until July 2029, depending on the level of waste generation. Commercial businesses must comply with the mandate and new development must be designed in a way to facilitate compliance with the mandate.

Type of Premises	General Waste Garbage Generation	Food Organics Generation	Recycling Generation
Food Premises			
Restaurants (Including good component of license premise).	528L*/100m ² floor area/day	132L/100m ² floor area/day	200 L/100m ² floor area/day
Supermarkets	528L*/100m ² floor area/day	132L/100m ² floor area/day	240 L/100m ² floor area/day
Greengrocer/Wholefoods store	528L*/100m ² floor area/day	30L/100m ² floor area/day N/A	120 L/100m ² floor area/day
Convenience Store	240L/100m ² floor area/day	30L/100m ² floor area/day N/A	150 L/100m ² floor area/day
Café	240L/100m ² floor area/day	60L/100m ² floor area/day	200 L/100m ² floor area/day
Take away/Café (pre-packaged)	12L/100m ² floor area/day	30L/100m ² floor area/day	150 L/100m ² floor area/day

Butcher	240 L/100m ² floor area/day	30L/100m ² floor area/day	50 L/100m ² floor area/day
Delicatessen	240L/100m ² floor area/day	30L/100m ² floor area/day N/A	50 L/100m ² floor area/day
Fish shop	240L*/100m ² floor area/day	30L/100m ² floor area/day	50 L/100m ² floor area/day
Minimum generation when no food business type is specified	150 L/100m ² floor area/day	30L/100m ² floor area/day	50 L/100m ² floor area/day
Non Food Premises			
Education and training	5L/100m ² floor area/day or 0.5L/student/week		5L/100m ² floor area/day or 0.5L/student/week
Offices	10L/100m ² floor area/day		10L/100m ² floor area/day
Shop (less than 100m ² floor area)	50L/100m ² floor area/day		25L/100m ² floor area/day
Shop (greater than 100m ² floor area)	50L/100m ² floor area/day		50L/100m ² floor area/day
Showroom	40L/100m ² floor area/day		10L/100m ² floor area/day
Warehouse	10L/100m ² floor area/day		10L/100m ² floor area/day
Childcare	80L/100m ² floor area/day		80L/100m ² floor area/day
Gym	10L/100m ² floor area/day		10L/100m ² floor area/day 50L (Penrith)
Hairdresser/Beauty Salon	60L/100m ² floor area/day		60L/100m ² floor area/day
Accomodation			
Student housing/Backpacker	40L/occupant/week		40L/occupant/week
Guesthouse	60L/occupant/week		60L/occupant/week
Hotel/Motel/Licensed club	5L/bed/day 50L/100m ² bar area/day 400L/100m ² dining area/day		5L/bed/day 50L/100m ² bar area/day 280L/100m ² dining area/day
Minimum generation when no non-food business type is specified	10L/100m ² floor area/day		10L/100m ² floor area/day

* Increase by 10% if waste oil is generated (from deep frying).

For commercial waste streams that are not outlined above, supporting documentation is required to validate the proposed volumes for the respective waste streams.

The generation rates for food organics were extracted from the City of Melbourne Guidelines published in 2021. Appropriate case study/empirical data may be used in place of generation rates above.

Annexure B1-3 Design Specification for Council Waste Collection Vehicles

Onsite Waste Facility Design Requirements For residential or mixed developments proposing on-site collection, the site entry point, vehicle route of travel and manoeuvring envelopes shall comply in general with the requirements of Australian Standard AS 2890.2 Parking Facilities Part 2: Off Street Commercial Vehicle Facilities (AS 2890.2).

The onsite waste facility shall cater for the following:

Design Vehicle	Requirement
Overall Length (m)	10.5
Operational Length (m)	12.5
Design Width (m)	2.8
Design Height (m)	3.7
Clearance (travel height) (m)	4.5
Weight Fully Loaded (tonnes)	22.5
Capacity (m ³)	24
Front Chassis Clearance	13°
Rear Chassis Clearance	16°

Annexure B1-4
Council Supplied Bin Dimensions

Bin Type	80L	140L	240L	660L
A (TOTAL HEIGHT)	840mm	915 mm	1060 mm	1220 mm
B (BIN HEIGHT)	795mm	870 mm	990 mm	1090 mm
C (BIN DEPTH)	480mm	550 mm	660 mm	740 mm
D (TOTAL DEPTH)	510mm	615 mm	730 mm	780 mm
E (WIDTH)	450mm	535 mm	585 mm	1210 mm
F (HANDLE WIDTH)	300mm	395 mm	400 mm	980 mm
G (WHEEL DIAMETER)	200mm	200 mm	200 mm	200 mm

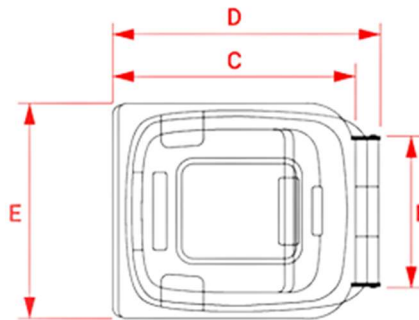
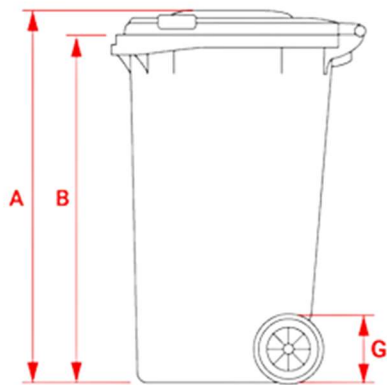

Source: Sulo Waste Management

Annexure B1-5 Composting and Worm Farming Guidelines

A composting facility must be provided in all residential use developments. Such facility may comprise either:

- A dedicated area on the site for the accommodation of a sufficient number of commercially available compost bins or worm farms, or
- A purpose designed compost area incorporated in the landscaped (low waste garden) area of the site.

Location

Conveniently accessible from all dwellings and reasonably close to the waste storage area. The facility should be located so as not to cause any nuisance to the occupants of the building on this or neighbouring sites.

Size

The capacity of compost bins for single dwellings is discretionary and will depend on the circumstances in the individual case. In new dwelling houses, an area of 1000mm x 1000mm should be provided.

In multi-residential buildings, provision should be made for:

- A dedicated area to accommodate sufficient compost bins having a minimum capacity of 30 litres for each dwelling unit; or
- A purpose designed compost structure having a minimum capacity of 1 cubic metre for every 6 dwelling units or part thereof.

Construction

A permanent compost facility may be three-sided, two-compartment structure made of solid timber or masonry, with a cover for weather protection.



Compost Bin

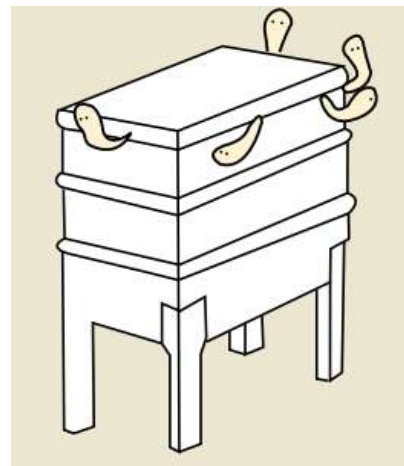

Worm Farm

Examples of composting and worm farming containers and structures

Note: More information is available at <http://compostrevolution.com.au/>

Where outdoor space is unavailable, smaller indoor composting systems are encouraged to be utilised within dwellings, and disposed of via Council's organic waste collection service.

**Annexure B1-6
Garbage Chutes, Compactors and Service Lifts Guidelines**

Garbage chute design

- Garbage chutes must be constructed in accordance with the requirements of the *National Construction Code*.
- Garbage chutes must be located and insulated in a manner that reduces noise impacts.
- Chutes, service openings and charging devices must be constructed of material (such as metal) that is smooth, durable, impervious, non-corrosive and fire resistant.
- Chutes, service openings and charging devices must be capable of being cleaned.
- Chutes must be cylindrical and should have a diameter of at least 500mm.
- There must not be any bends (or sections of reduced diameter) in the shaft of the chute.
- Internal overlaps in the chute must follow the direction of waste flow.
- Chutes must deposit rubbish directly into a bin or compactor located within a waste/recycling storage room.
- A cut-off device must be located at or near the base of the chute so the bottom of the chute can be closed when the bin or compacting device at the bottom of the chute is withdrawn or being replaced.
- The upper end of a chute should extend above the roofline of the building.
- The upper end of a chute should be weather protected in a manner that doesn't impede the upward movement of air out of the chute.

Garbage chute service room design

- The service opening (for depositing rubbish into the main chute) on floor of the building must be located in a dedicated service room.
- The charging device for each service opening must be self-closing and project into the main chute.
- Branches connecting service openings to the main chute are to be no more than 1m long.
- Each service room must include containers for the storage of recyclable materials. Signage regarding the materials that can be recycled should be displayed near these containers.
- Each service room must be located for convenient access by users and must be well ventilated and well lit.
- The floors, walls and ceilings of service rooms must be finished with smooth, durable materials that are capable of being easily cleaned.
- Service rooms must include signage that clearly describes the types of materials that can be deposited into the garbage chute and the types of materials which should be deposited into recycling bins.

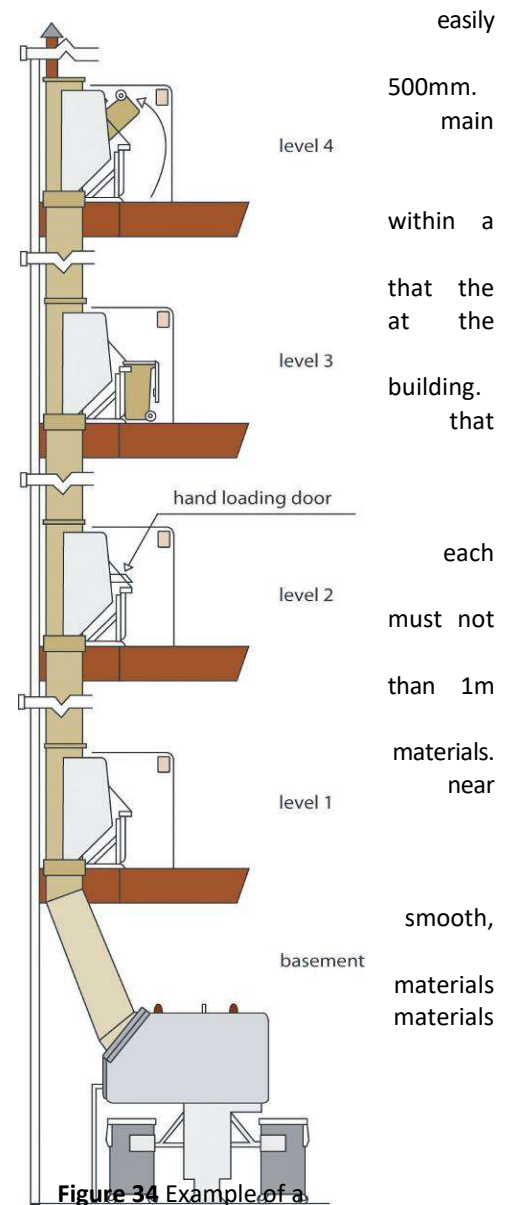

Figure 34 Example of a garbage chute system

Management

- Garbage chutes are not to be used for the disposal of recyclable materials. Signage to this effect should be displayed near service openings.
- Arrangements must be in place for the regular maintenance and cleaning of garbage chutes and any associated service rooms, service openings and charging devices.
- Arrangements must be in place for the regular transferal of recyclable materials (which are stored in service rooms) to the main waste/recycling storage room.

Service Lifts

- A service lift (or service elevator) may be appropriate in place of a waste chute in developments where a caretaker is to be employed.
- A service lift is a dedicated elevator system for the transport of waste and recycling containers and other equipment required for the operation of the development.
- A waste service compartment must be provided on each floor of the development to allow residents to store waste and recyclables.
- Residents place their waste and recyclables in bins provided and these are transported daily by the caretaker to the waste storage room.
- Each service room must be designed with sufficient space for the storage of two days waste and recycling for all residents on that level.
- Applicants will need to check with Council whether this option is acceptable.

Compactors

- Compactors are used to compress the waste (or recyclables) into smaller collection containers.
- The compaction ratio is typically set at around 2:1. Higher ratios are not used as they may result in heavier bins, causing OH&S problems, mechanical damage and breakage of recyclable materials.
- Best practice compaction systems compact directly into a 240 litre bin or a skip, reducing the requirement of manually loading the compacted waste into bins or skips.
- Compactors are extremely useful for mixed garbage, if used for recyclables extreme care must be taken not to cross contaminate the recycling streams.
- Compactors are less useful for steel containers and should not be used for glass.
- Compactors require regular maintenance. In particular, systems fed from a chute can be prone to blockages or failure of the “electronic eye”, which can result in garbage overflowing or backing up the chute. As a result if the 2:1 compaction ratio, the requirement for garbage storage bins is halved. This information was sourced from: Resource NSW (The Department of the Environment and Conservation), “Better Practice Guide for Waste Management in Multi-Unit Dwellings”, 2002.

Source: *Better Practice Guide for Waste Management in Multi-Unit Dwellings*, DECC, 2008.

Annexure B1-7**Placing a Waste Storage Container in a Public Place**

To place a waste storage container (skip) in a public place, such as on a roadway or footpath, a Building Waste Container Company registered with Council must be used.

For the purposes of this Part, a waste storage container means a bulk container, commonly known as a skip, that is used for the temporary storage and transportation (by a registered vehicle) of waste and recycling materials generated by building demolition and construction activities, as well as general household rubbish. Also for the purposes of this Part, a public place means the whole of a public roadway, including any footway and grass verge, but does not include a public park or reserve which is land used for public recreation and like purposes.

A waste container may be placed in a public place, only where there is no suitable space available on the user's premises. Council permits this to encourage source separation and recycling of waste materials. Council encourages the use of multiple containers or careful scheduling of single container collections to enable separation of re-useable and recyclable materials. Details of the container must be marked on the plans presented to Council when applying for a construction certificate.

Approval Requirements

Permission to supply and locate a building waste container / skip is granted subject to compliance with the following conditions:

1. The Company holds a current Council permit to place a waste storage container in a public place;
2. The Company have lodged an appropriate security deposit with Council to cover the costs for repair of any damage caused to public property;
3. Containers will be positioned in conformity with the "Interim Guidelines for the Placement of Building Waste Containers" as prepared by the Roads and Traffic Authority of N.S.W;
4. Containers shall not exceed a width of 2.5m;
5. No containers shall be located in a public reserve without the prior approval of Council;
6. Containers shall not be left on a roadway longer than seven (7) days;
7. Containers shall bear the name and telephone number of the supplier;
8. Suppliers agree that the site where containers are being placed will be left in a clean and tidy condition with all spillage removed from the area;
9. Suppliers are to be responsible for any incidence of damage arising from poor placement of containers or spilt debris; and
10. Suppliers are to agree in writing to indemnify Council against any public liability claim arising from the placement of containers on Council's roadways and such insurance cover to indemnify Waverley Council for a minimum amount of \$10,000,000.

When placing a waste storage container / skip in a public place the following provisions must be complied with:

1. Public safety and convenience must be preserved;
2. The container will not cause any damage to public property;
3. The container is a size appropriate to the location;
4. The container is clearly identifiable;
5. The container is clearly visible to traffic;
6. The container does not restrict or obstruct traffic visibility;
7. The container does not disturb or obstruct the free flow of pedestrian or vehicular traffic; and
8. The container does not disturb normal stormwater flow.

Annexure B3-1 Planting List

All species on this list are generally recommended for use throughout Waverley, however, the selection of appropriate plant species for each site should be recommended by a suitably qualified landscape or bushland regeneration professional. Alternative species may be approved by Council.

It is strongly recommended that the sourcing of plant material is undertaken well in advance of any development to ensure availability of species required.

Please note that Hedging of any *trees* (such as Lilly Pillies) will result in their classification as shrubs for the purposes of applying these controls. Note that some of the species in the *shrubs medium – large* section can be classified as trees, depending on their height at maturity and number of stems.

TREES	
Botanical Name	Common Name
<i>Acacia decurrens</i>	Sydney Green Wattle
<i>Acacia implexa</i>	Hickory Wattle
<i>Acacia irrorata ssp. irrorata</i>	Green Wattle
<i>Acacia longissiuma</i>	Long-leaf Wattle
<i>Acacia parramattensis</i>	Sydney Green Wattle
<i>Acmena smithii</i>	Lilly Pilly
<i>Acronychia oblongifolia</i>	White Aspen
<i>Allocasuarina littoralis</i>	Black She-oak
<i>Allocasuarina torulosa</i>	Forest Oak
<i>Angophora costata</i>	Sydney Red Gum
<i>Angophora hispida</i>	Dwarf Apple
<i>Archontophoenix cunninghamiana</i>	Bangalow Palm
<i>Backhousia citriodora</i>	Lemon Myrtle
<i>Backhousia myrtifolia</i>	Grey Myrtle
<i>Banksia integrifolia</i>	Coastal Banksia
<i>Banksia marginata</i>	Silver Banksia
<i>Callicoma serratifolia</i>	Black Wattle
<i>Casuarina glauca</i>	Swamp Sheoak
<i>Ceratopetalum apetalum</i>	Coachwood
<i>Corymbia gummifera</i>	Red Bloodwood
<i>Cupaniopsis anacardioides</i>	Tuckeroo
<i>Elaeocarpus reticulatus</i>	Blueberry Ash
<i>Enidandra sieberi</i>	Corkwood
<i>Eucalyptus botryoides</i>	Bangalay
<i>Eucalyptus gummifera</i>	Red Bloodwood
<i>Eucalyptus haemastoma</i>	Scribbly Gum
<i>Eucalyptus piperita</i>	Sydney Peppermint
<i>Eucalyptus obstans</i>	Port Jackson Mallee
<i>Eucalyptus robusta</i>	Swamp Mahogany
<i>Ficus rubiginosa</i>	Port Jackson Fig
<i>Ficus coronata</i>	Sandpaper Fig
<i>Glochidion ferdinandi</i>	Cheese Tree
<i>Hymenosporum flavum</i>	Native Frangipani

<i>Livistona australis</i>	<i>Cabbage Palm</i>
<i>Melia azederach var. australasica</i>	<i>White Cedar</i>
<i>Notelaea longifolia</i>	<i>Large Mock-olive</i>
<i>Pittosporum revolutum</i>	<i>Yellow Pittosporum</i>
<i>Podocarpus elatus</i>	<i>Plum Pine</i>
<i>Syzygium leuhmannii</i>	<i>Riberry</i>
<i>Syzygium paniculatum</i>	<i>Magenta Lilly Pilly</i>
<i>Syncarpia glomulifera ssp glomulifera</i>	<i>Turpentine</i>
<i>Toona ciliata</i>	<i>Red Cedar</i>
<i>Tristainiopsis laurina</i>	<i>Water Gum</i>

SHRUBS: Medium-Large	
Botanical Name	Common Name
<i>Acacia binervia</i>	<i>Coast Myall</i>
<i>Acacia linifolia</i>	<i>White Wattle</i>
<i>Acacia longifolia</i>	<i>Sydney Golden Wattle</i>
<i>Acacia floribunda</i>	<i>White Sally Wattle</i>
<i>Acacia sophorae</i>	<i>Coastal Wattle</i>
<i>Acacia terminalis</i>	<i>Sunshine Wattle</i>
<i>Allocasuarina distyla</i>	<i>Shrubby She-oak</i>
<i>Banksia aemula</i>	<i>Wallum Banksia</i>
<i>Banksia ericifolia</i>	<i>Heath-leaved Banksia</i>
<i>Banksia oblongifolia</i>	<i>Fern-leaved Banksia</i>
<i>Banksia marginata</i>	<i>Silver Banksia</i>
<i>Banksia serrata</i>	<i>Old Man Banksia</i>
<i>Callistemon linearifolius</i>	<i>Netted Bottlebrush</i>
<i>Callistemon pinifolius</i>	<i>Pine-leaved Bottlebrush</i>
<i>Callistemon salignus</i>	<i>Willow Bottlebrush</i>
<i>Ceratopetalum gummiferum</i>	<i>NSW Christmas Bush</i>
<i>Cordyline stricta</i>	<i>Slender Palm Lily</i>
<i>Cyathea cooperi</i>	<i>Rough Tree Fern</i>
<i>Dicksonia antarctica</i>	<i>Soft Tree Fern</i>
<i>Eupomatia laurina</i>	<i>Bolwarra</i>
<i>Grevillea linearifolia</i>	<i>Linear-leaf Grevillea</i>
<i>Grevillea mucronulata</i>	<i>Green Spider Flower</i>
<i>Grevillea speciosa</i>	<i>Red Spider Flower</i>
<i>Grevillea sphacelata</i>	<i>Grey Spider Flower</i>
<i>Hakea dactyloides</i>	<i>Finger Hakea</i>
<i>Hakea gibbosa</i>	<i>Needlebush</i>
<i>Hakea teretifolia</i>	<i>Dagger Hakea</i>
<i>Kunzea ambigua</i>	<i>Tick Bush</i>
<i>Lambertia formosa</i>	<i>Mountain Devil</i>
<i>Leptospermum laevigatum</i>	<i>Coastal Tea Tree</i>
<i>Leptospermum polygalifolium</i>	<i>Yellow tea-tree</i>
<i>Leptospermum squarrosus</i>	<i>Pink tea-tree</i>

<i>Lomatia myricoides</i>	River Lomatia
<i>Melaleuca armillaris</i>	Bracelet Honey-myrtle
<i>Melaleuca linariifolia</i>	Flax-leaved Paperbark
<i>Melaleuca nodosa</i>	Ball Honey-myrtle
<i>Monotoca elliptica</i>	Tree Broom-heath
<i>Myrsine variabilis</i>	Variable Muttonwood
<i>Persoonia levis</i>	Broad-leaved Geebung
<i>Persoonia linearis</i>	Narrow-leaved Geebung
<i>Polyscias sambucifolia</i>	Elderberry Panax
<i>Viminaria juncea</i>	Native Broom

SHRUBS: Small-Medium	
Botanical Name	Common Name
<i>Acacia myrtifolia</i>	Myrtle Wattle
<i>Acacia longifolia</i> ssp. <i>sophorae</i>	Coastal Wattle
<i>Acacia suaveolens</i>	Sweet Wattle
<i>Acacia terminalis</i>	Sunshine Wattle
<i>Acacia ulicifolia</i>	Prickly Moses
<i>Baeckea imbricata</i>	Heath Myrtle
<i>Baeckea linifolia</i>	Swamp Baeckea
<i>Banksia robur</i>	Swamp Banksia
<i>Banksia spinulosa</i>	Hair-pin Banksia
<i>Bauera rubioides</i>	River Dog Rose
<i>Bossiaea heterophylla</i>	Variable bossiaea
<i>Brachyloma daphnoides</i>	Daphne Heath
<i>Breynia oblongifolia</i>	Coffee Bush
<i>Callistemon citrinus</i>	Crimson Bottlebrush
<i>Callistemon linearis</i>	Narrow-leaved Bottlebrush
<i>Correa alba</i>	Coastal Correa
<i>Correa reflexa</i>	Native Fuchsia
<i>Crocea saligna</i>	Crocea
<i>Darwinia fascicularis</i>	Darwinia
<i>Dillwynia retorta</i>	Parrot Pea
<i>Dodonaea triquetra</i>	Common Hop Bush
<i>Eriostemon australasius</i>	Pink Wax Flower
<i>Grevillea linearifolia</i>	Linear-leaf Grevillea
<i>Grevillea mucronulata</i>	Green Spider Grevillea
<i>Grevillea speciosa</i>	Red Spider Grevillea
<i>Grevillea sphacelata</i>	Grey Spider Grevillea
<i>Lambertia formosa</i>	Mountain Devil
<i>Lasiopetalum ferrugineum</i>	Rusty Petals
<i>Lomatia silaifolia</i>	Crinkle Bush
<i>Melaleuca thymifolia</i>	Thyme Honey-myrtle
<i>Olearia tomentosa</i>	Daisy Bush
<i>Ozothamnus diosmifolius</i>	Rice Blower

<i>Pimelea linifolia</i>	<i>Slender Rice flower</i>
<i>Platysace lanceolata</i>	<i>Native Parsnip</i>
<i>Phebalium squamulosum</i>	<i>Forest Phebalium</i>
<i>Prostanthera incisa</i>	<i>Toothed Mint Bush</i>
<i>Pultenaea linophylla</i>	<i>Halo Bush Pea</i>
<i>Ricinocarpus pinifolius</i>	<i>Wedding Bush</i>
<i>Westringia fruticosa</i>	<i>Coastal Rosemary</i>

GRASSES and GROUNDCOVERS – Upright Grasses, Lillies, Rushes and Sedges	
Botanical Name	Common Name
<i>Alocasia brisbanensis</i>	<i>Cunjevoi</i>
<i>Austrostipa pubescens</i>	<i>Spear Grass</i>
<i>Baumea juncea</i>	<i>Bog Rush</i>
<i>Crinum pedunculatum</i>	<i>Swamp Lily</i>
<i>Cymbopogon refractus</i>	<i>Barbed Wire Grass</i>
<i>Dianella caerulea</i>	<i>Blue Flax Lily</i>
<i>Dianella congesta</i>	<i>Coastal Flax Lily</i>
<i>Dianella revoluta</i>	<i>Paroo Lily</i>
<i>Dichelachne crinita</i>	<i>Long Hair Plume Grass</i>
<i>Dichelachne micrantha</i>	<i>Short Hair Plume Grass</i>
<i>Echinopogon caespitosus</i>	<i>Tufted Hedgehog Grass</i>
<i>Entolasia marginata</i>	<i>Bordered panic Grass</i>
<i>Entolasia stricta</i>	<i>Wiry Panic Grass</i>
<i>Ficinia nodosa</i>	<i>Knobby Club Rush</i>
<i>Gahnia sieberiana</i>	<i>Saw Sedge</i>
<i>Imperata cyllindrica</i>	<i>Blady Grass</i>
<i>Juncus usitatus</i>	<i>Common Rush</i>
<i>Juncus krausii</i>	<i>Sea Rush</i>
<i>Lachnagrostis billardierei</i>	<i>Coast Blown Grass</i>
<i>Lomandra longifolia</i>	<i>Spiny-headed Mat rush</i>
<i>Machaerina juncea</i>	<i>Bare Twig-rush</i>
<i>Paspalidium distans</i>	<i>Shotgrass</i>
<i>Poa affinis</i>	<i>Tussock Grass</i>
<i>Rytidosperma fulvum</i>	<i>Wallaby Grass</i>
<i>Themeda australis</i>	<i>Kangaroo Grass</i>
<i>Themeda australis</i> Coastal form	<i>Kangaroo Grass (Coastal Form)</i>
<i>Xanthorrhoea resinosa</i>	<i>Grass Tree</i>

GRASSES and GROUNDCOVERS – Herbs and Subshrubs	
Botanical Name	Common Name
<i>Austromyrtus tenuifolia</i>	<i>Midgenberry</i>
<i>Brachyloma daphnoides</i>	<i>Daphne Heath</i>
<i>Geranium homeanum</i>	<i>Cranesbill</i>
<i>Gonocarpus teucrioides</i>	<i>Germander Raspwort</i>
<i>Homoranthus flavescens</i>	<i>Homoranthus</i>

<i>Leucopogon ericoides</i>	<i>Pink Beard-heath</i>
<i>Leucopogon juniperinus</i>	<i>Prickly Beard-heath</i>
<i>Lomandra glauca</i>	<i>Pale Mat-rush</i>
<i>Lomatia silafolia</i>	<i>Crinkle Bush</i>
<i>Mirbelia rubiifolia</i>	<i>Heathy Mirbelia</i>
<i>Pelargonium australe</i>	<i>Austral Stork's Bill</i>
<i>Plectranthus parviflorus</i>	<i>Cockspur flower</i>
<i>Wahlengergia gracilis</i>	<i>Sprawling Bluebell</i>
<i>Xerochrysum bracteatum</i>	<i>Paper Daisy</i>

GRASSES and GROUNDCOVERS – Climbers and Twiners

Botanical Name	Common Name
<i>Billardiera scandens</i>	<i>Hairy Appleberry</i>
<i>Cissus antarctica</i>	<i>Kangaroo Vine</i>
<i>Cissus hypoglauca</i>	<i>Five-leaf Water Vine</i>
<i>Eustrephus latifolius</i>	<i>Wombat Berry</i>
<i>Geitonoplesium cymosum</i>	<i>Scrambling Lily</i>
<i>Glycine clandestina</i>	<i>Love Creeper</i>
<i>Gynochthodes jasminoides</i>	<i>Sweet Morinda</i>
<i>Hardenbergia violacea</i>	<i>False Sarsaprilla</i>
<i>Hibbertia dentata</i>	<i>Trailing Guinea-flower</i>
<i>Hibbertia scandens</i>	<i>Golden Guinea Flower</i>
<i>Hoya australis</i>	<i>Australian Wax Plant</i>
<i>Pandorea pandorana</i>	<i>Wonga Wonga Vine</i>
<i>Smilax glycyphylla</i>	<i>Sweet Sarsaparilla</i>
<i>Stephania japonica</i> var. <i>discolor</i>	<i>Snake Vine</i>

GRASSES and GROUNDCOVERS – Low grasses and groundcovers

Botanical Name	Common Name
<i>Carpobrotus glaucescens</i>	<i>Pig Face</i>
<i>Carex pumila</i>	<i>Strand Sedge</i>
<i>Centella asiatica</i>	<i>Gotu Cola</i>
<i>Commelina cynaea</i>	<i>Scurvy Weed</i>
<i>Dichondra repens</i>	<i>Kidney Weed</i>
<i>Eragrostis brownii</i>	<i>Blown Grass</i>
<i>Lomandra glauca</i>	<i>Pale Mat-Rush</i>
<i>Microleana stipoides</i>	<i>Weeping Grass</i>
<i>Oplismenus aemulus</i>	<i>Basket Grass</i>
<i>Oplismenus imbecillis</i>	<i>Basket Grass</i>
<i>Scaevola calendulacea</i>	<i>Coastal Fan Flower</i>
<i>Selleria radicans</i>	<i>Swamp Weed</i>
<i>Tetragonia tetragonioides</i>	<i>Warrigal Greens</i>
<i>Viola hederacea</i>	<i>Native Violet</i>
<i>Zoysia macranthra</i>	<i>Prickly Marine Couch</i>

GRASSES and GROUNDCOVERS – Ferns

Botanical Name	Common Name
<i>Adiantum aethiopicum</i>	Maidenhair Fern
<i>Asplenium australasicum</i>	Birds Nest Fern
<i>Calochlaena dubia</i>	Soft Bracken
<i>Doodia aspera</i>	Rasp Fern
<i>Histiopteris incisa</i>	Bats Wing Fern
<i>Hypolepis muelleri</i>	Harsh Ground Fern
<i>Pellaea falcata</i>	Sickle fern
<i>Pteridium esculentum</i>	Common Bracken
<i>Sticherus flabellatus</i>	Umbrella Fern

Annexure B3-2 Tree Canopy Replacement Planting List

Replacement Plantings	
Botanical Name	Common Name
<i>Araucaria columnaris</i>	Cook Island Pine or New Caledonia Pine
<i>Araucaria heterophylla</i>	Norfolk Island Pine
<i>Casuarina equisetifolia</i>	Horsetail Casuarina
<i>Livistona australis</i>	Cabbage Tree Palm
<i>Melaleuca armillaris</i>	Bracelet Honey Myrtle
<i>Melaleuca lanceolata</i>	Moonah
<i>Metrosideros spp</i>	New Zealand Christmas Bush
<i>Washingtonia robusta</i>	Cotton Palm
<i>Acacia decurrens</i>	Sydney Green Wattle
<i>Acacia fimbriata</i>	Fringed Wattle
<i>Acacia implexa</i>	Hickory Wattle
<i>Acacia irrorata ssp. irrorata</i>	Green Wattle
<i>Acacia longissima</i>	Long-leaf Wattle
<i>Acacia parramattensis</i>	Sydney Green Wattle
<i>Acacia sophorae</i>	Coastal Wattle
<i>Acmena ingens</i>	Red Apple
<i>Acmena smithii</i>	Lilly Pilly
<i>Acronychia oblongifolia</i>	White Aspen
<i>Agonis flexuosa 'After Dark'</i>	Purple-leafed Willow Myrtle
<i>Alectryon coriaceus</i>	Beach Birds Eye
<i>Allocasuarina littoralis</i>	Black She-oak
<i>Allocasuarina torulosa</i>	Forest Oak
<i>Angophora costata</i>	Sydney Red Gum
<i>Angophora hispida</i>	Dwarf Apple
<i>Araucaria columnaris</i>	Cook Island Pine or New Caledonia Pine
<i>Araucaria heterophylla</i>	Norfolk Island Pine
<i>Archontophoenix cunninghamiana</i>	Bangalow Palm
<i>Backhousia citriodora</i>	Lemon Myrtle
<i>Backhousia myrtifolia</i>	Grey Myrtle
<i>Banksia integrifolia</i>	Coastal Banksia
<i>Banksia marginata</i>	Silver Banksia

<i>Banksia serrata</i>	Old Man Banksia
<i>Brachychiton acerifolius</i>	Illawarra Flame Tree
<i>Buckinghamia celsissima</i>	Ivory Curl Tree
<i>Callicoma serratifolia</i>	Black Wattle
<i>Callistemon</i>	Bottlebrush
<i>Callistemon 'Dawson River'</i>	Weeping Bottlebrush
<i>Callistemon citrinus</i> *	Lemon-Scented Bottlebrush
<i>Callistemon 'Dawson River'</i>	Weeping Bottlebrush
<i>Callistemon salignus</i>	Willow Bottlebrush
<i>Callitris rhomboidea</i>	Port Jackson Pine
<i>Casuarina glauca</i>	Swamp Sheoak
<i>Ceratopetalum gummiferum</i>	NSW Christmas Bush
<i>Ceratopetalum apetalum</i>	Coachwood
<i>Corymbia eximia</i>	Yellow Bloodwood
<i>Corymbia gummifera</i>	Red Bloodwood
<i>Cupaniopsis anacardioides</i>	Tuckeroo
<i>Elaeocarpus reticulatus</i>	Blueberry Ash
<i>Enidandra sieberi</i>	Corkwood
<i>Eucalyptus 'Summer Red'</i>	Eucalyptus Summer Red & cultivars
<i>Eucalyptus botryoides</i>	Bangalay
<i>Eucalyptus gummifera</i>	Red Bloodwood
<i>Eucalyptus haemastoma</i>	Scribbly Gum
<i>Eucalyptus obstans</i>	Port Jackson Mallee
<i>Eucalyptus piperita</i>	Sydney Peppermint
<i>Eucalyptus robusta</i>	Swamp Mahogany
<i>Ficus coronata</i>	Sandpaper Fig
<i>Ficus rubiginosa</i>	Port Jackson Fig
<i>Geijera parviflora</i>	Wilga
<i>Gleditsia triacanthos</i>	Honey Locust
<i>Glochidion ferdinandi</i>	Cheese Tree
<i>Hibiscus 'Rubra'</i>	Red-leafed Hibiscus Tree
<i>Hymenosporum flavum</i>	Native Frangipani
<i>Koelreuteria paniculata</i>	Golden Rain Tree
<i>Leptospermum laevigatum</i>	Coastal Tea Tree
<i>Livistona australis</i>	Cabbage Tree Palm
<i>Lophostemon confertus</i>	Brushbox
<i>Magnolia grandiflora</i>	Bull-Bay Magnolia
<i>Melaleuca armillaris</i>	Bracelet Honey Myrtle
<i>Melaleuca decora</i>	White Feather Honey Myrtle
<i>Melaleuca leucadendra</i>	Fine-leafed Paperbark
<i>Melaleuca quinquenervia</i>	Broad-leafed Paperbark
<i>Melaleuca styphelioides</i>	Prickly Paperbark
<i>Melia azederach var. australasica</i>	White Cedar
<i>Metrosideros spp</i>	New Zealand Christmas Bush
<i>Notelaea longifolia</i>	Large Mock-olive
<i>Pittosporum revolutum</i>	Yellow Pittosporum
<i>Podocarpus elatus</i>	Plum Pine
<i>Stenocarpus sinuatus</i>	Firewheel Tree
<i>Sygyium leuhmannii</i>	Riberry

<i>Sygyium paniculatum</i>	Magenta Lilly Pilly
<i>Syncarpia glomulifera ssp glomulifera</i>	Turpentine
<i>Syzygium luehmannii</i>	Riberry
<i>Toona ciliata</i>	Red Cedar
<i>Tristainiopsis laurina</i>	Water Gum
<i>Tristaniopsis laurina</i>	Watergum
<i>Washingtonia robusta</i>	Cotton Palm
<i>Waterhousea floribunda</i>	Waterhousea

Annexure B5-1 Flood Compatible Material

Table 1 List of suitable flood compatible materials

Building Component	
Flooring and sub-floor	<ul style="list-style-type: none"> Concrete slab-on-ground monolith
	<ul style="list-style-type: none"> suspended reinforced concrete slab
Floor covering	<ul style="list-style-type: none"> clay tiles
	<ul style="list-style-type: none"> concrete, precast or in situ
	<ul style="list-style-type: none"> concrete tiles
	<ul style="list-style-type: none"> epoxy, formed-in-place
	<ul style="list-style-type: none"> mastic flooring, formed-in-place
	<ul style="list-style-type: none"> rubber sheets or tiles with chemicals-set-adhesive
	<ul style="list-style-type: none"> silicone floors formed-in-place
	<ul style="list-style-type: none"> vinyl sheets or tiles with chemical-set adhesive
	<ul style="list-style-type: none"> ceramic tiles, fixed with mortar or chemical-set
	<ul style="list-style-type: none"> asphalt tiles, fixed with water resistant adhesive
	<ul style="list-style-type: none"> asphalt tiles, fixed with water resistant adhesive
Wall structure	<ul style="list-style-type: none"> Solid brickwork, block work, reinforced, concrete or
Roofing structure (for situations where the relevant flood level is	<ul style="list-style-type: none"> reinforced concrete construction galvanised metal construction
Doors	<ul style="list-style-type: none"> solid panel with water proof adhesives
	<ul style="list-style-type: none"> flush door with marine ply filed with cell foam
	<ul style="list-style-type: none"> painted metal construction
	<ul style="list-style-type: none"> aluminium or galvanised steel frame
Wall and ceiling linings	<ul style="list-style-type: none"> fibro-cement board
	<ul style="list-style-type: none"> brick face or glazed
	<ul style="list-style-type: none"> clay tile glazed in waterproof mortar
	<ul style="list-style-type: none"> concrete
	<ul style="list-style-type: none"> concrete block
	<ul style="list-style-type: none"> steel with waterproof applications
	<ul style="list-style-type: none"> stone, natural solid or veneer, waterproof grout
	<ul style="list-style-type: none"> glass blocks
	<ul style="list-style-type: none"> glass
	<ul style="list-style-type: none"> plastic sheeting or wall with waterproof adhesive
Insulation windows	<ul style="list-style-type: none"> Foam (closed cell types)
	<ul style="list-style-type: none"> Aluminium frame with stainless steel rollers or similar corrosion and water-resistant material
Nails, bolts, hinges and fittings	<ul style="list-style-type: none"> Brass, nylon or stainless steel;
	<ul style="list-style-type: none"> Removable pin hinges
	<ul style="list-style-type: none"> Hot dipped galvanised steel wire nails or similar.

Electrical and mechanical equipment	
<i>For dwellings constructed on land to which this DCP applies, the electrical and mechanical materials, equipment and installation must conform to the following requirements:</i>	
Main power supply	Subject to the approval of the relevant authority the incoming main commercial power service equipment, including all metering equipment, must be located above the design flood level. Means must be available to easily disconnect the dwelling from the main power supply.
Wiring	All wiring, power outlets, switches, must be to the maximum extent possible, located above the probably maximum flood level. All electrical wiring installed below this level must be suitable for continuous underwater immersion and must contain no fibrous components. Earth leakage circuit-breaker (core balance relays) or a residual Current Device must be installed. Only submersible type splices must be used below the probably maximum flood level. All conduits located below the relevant design flood level must be so installed that they will be self-draining if subjected to flooding.
Equipment	All equipment installed below or partially below the design flood level must be capable of disconnection by a single plug and socket assembly.
Reconnection	Should any electrical device and/or part of the wiring be flooded it must be thoroughly cleaned or replaced and checked by an approved electrical contractor before reconnection.
Heating and air conditioning systems	
<i>Where viable, heating and air conditioning systems should be installed in areas and spaces of the house above the probably maximum flood level. If this is not feasible, every precaution must be taken to minimise the damage caused by submersion according to the following guidelines:</i>	
Fuel	Heating systems using gas or oil as fuel must have a manually operated valve located in the fuel supply line to enable fuel cut-off.
Installation	Heating equipment and fuel storage tanks must be mounted on and securely anchored to a foundation pad of sufficient mass to overcome buoyancy and prevent movement that could damage the fuel supply line. All storage tanks must be vented to an elevation of 600 millimetres above the design flood level.
Ducting	All ductwork located below the design flood level must be provided with openings for drainage and cleaning. Self-draining may be achieved by constructing the ductwork on a suitable grade. Where ductwork must pass through a water-tight wall or floor below the design flood level, a closure assembly operated from above the design flood level must protect the ductwork.

Note: The above list is not considered to be exhaustive and other materials and methods can be proposed for Council's consideration as part of any application

Annexure B5-2
Flood Impact Assessment Requirements**General**

A Flood Impact and Risk Assessment (FIRA) must be prepared by a professional engineer who specialises in hydraulic engineering. The FIRA must be prepared in accordance with the relevant sections of this Chapter. Applicants are referred to guidance provided by “Flood impact and risk assessment - Flood risk management guideline LU01” (2023 NSW Department of Planning and Environment) or any amended version or future equivalent replacement document, for detailed guidance for the preparation of a FIRA.

The assessment of impacts should be fit for purpose. Computer modelling may not be required in all circumstances, subject to Council’s advice.

Flood frequencies to be considered

A minimum of the 5% AEP, 1% AEP and PMF flood events must be modelled to assess the impact on existing flood conditions of a proposed development to property, infrastructure and the environment.

When is a FIRA required?

A FIRA may be required for any type of development where the development occurs in the floodplain (i.e. situated within the Flood Planning Area). A FIRA may also be required where the site in question is identified as a Flood Control Lot as defined in *State Environmental Planning Policy (Exempt and Complying Development Codes)* to aid in the application of the State Environmental Planning Policy.

For the purposes of Council being satisfied that a FIRA is not required, Council will consider the context of the proposed development and site characteristics, inclusive of the following criteria:

- the development will be designed to not obstruct the flow of flood waters
- the development will not materially change existing pervious ground surfaces to impervious ground surfaces
- the development is not located in a floodway or storage area.

Computer Model

Unless it can be demonstrated that hydraulic modelling is not required, the FIRA must be prepared using Council’s TUFLOW model. Once engaged, the consultant must enter into a license agreement for the use of Council’s flood model for the specific purpose of preparing the FIRA for the proposed development only.

Note: a fee is payable for the use of the TUFLOW model.

Flood Impact Assessment Criteria

The following criteria should be applied as part of the consideration of determining whether a development will have a material impact on other developments or land:

- The flood impact of the development should not exceed a maximum increase of 10mm on land not associated with the development in a 1% AEP flood.
- The flood impact of the development should not exceed a maximum increase of 20mm on land not associated with the development in a 5% AEP flood.
- The development should not result in flood flow velocities increasing at the property boundary for any flood up to a 1% AEP flood:
 - by any amount where the existing condition flow velocity is greater than 1.5 m/s, or
 - by more than 20% where the existing flow velocity is less than 1.5 m/s.
- The development should not result in the change in hazard classification in a 1% AEP flood on adjoining private or public land.

Shelter in Place considerations

Where sheltering in place is required to the prescriptive controls of the DCP, the FIRA shall include an assessment of whether the proposal provides an acceptable flood refuge area. The assessment shall have regard to the “Shelter-in-Place Guideline for Flash Flooding” (Department of Planning, Housing & Infrastructure, 2024) and incorporate the following design features:

- floor level to be above the PMF
- within a building that is structurally sound in all floods up to and including a PMF
- access to the refuge is self-directing and accessible for all likely occupants without reliance on mains electricity
- weather protection.

For residential development involving more than a single dwelling house and for non-residential development where 5 or more occupants might be required to shelter in place, the additional design features are to be included:

- the refuge is sized for a minimum 2m² of floor area per likely occupant
- appropriate means to regulate thermal comfort (eg heating, blankets, etc)
- personal hygiene facilities (access to toilet facilities)
- emergency survival pack that is checked and renewed annually (incorporating supplies such as a medical kit, food, water, fire extinguisher, radio, lighting, batteries and/or on-site power systems).

FIRA Report

The FIRA must address the following:

- Description of the Site (including existing stormwater drainage and local catchment characteristics) and details of the proposed development.
- Flood affectation to the Site and surrounding land during the 5% AEP, 1% AEP and PMF events under existing (i.e. pre-development) conditions.



- Flood affectation to the Site and surrounding land during the 5% AEP, 1% AEP and PMF events under post-development conditions.
- Overview of the change in flood conditions associated with the proposed development.
- Overview of the Flood Risk Precinct(s) and associated development controls applicable to the Site for pre and post development conditions.
- Discussion of adherence to applicable planning controls.
- Proposed mitigation measures to address any impacts or minimise risk to personal safety of occupants and the risk of property damage.
- A flood evacuation strategy (Flood Emergency Response Plan) (if required).
- On site response plan to minimise flood damage and provide adequate storage areas for hazardous materials and valuable goods above the flood level (if required).
- The architectural/engineering plans on which the assessment is based.
- Supporting calculations and mapping.
- The professional qualifications and experience of the author(s).

The FIRA shall be prepared and submitted for the proposed development as part of a development application. In the event the plans and associated reports are updated as part of the assessment process, the FIRA shall be updated to reflect the current version of the proposed development. RLs that reflect AEP flood levels are required to demonstrate compliance with the DCP controls and shall be clearly shown on the development application plans.

The FIRA must include maps and analysis that clearly demonstrate the above considerations.

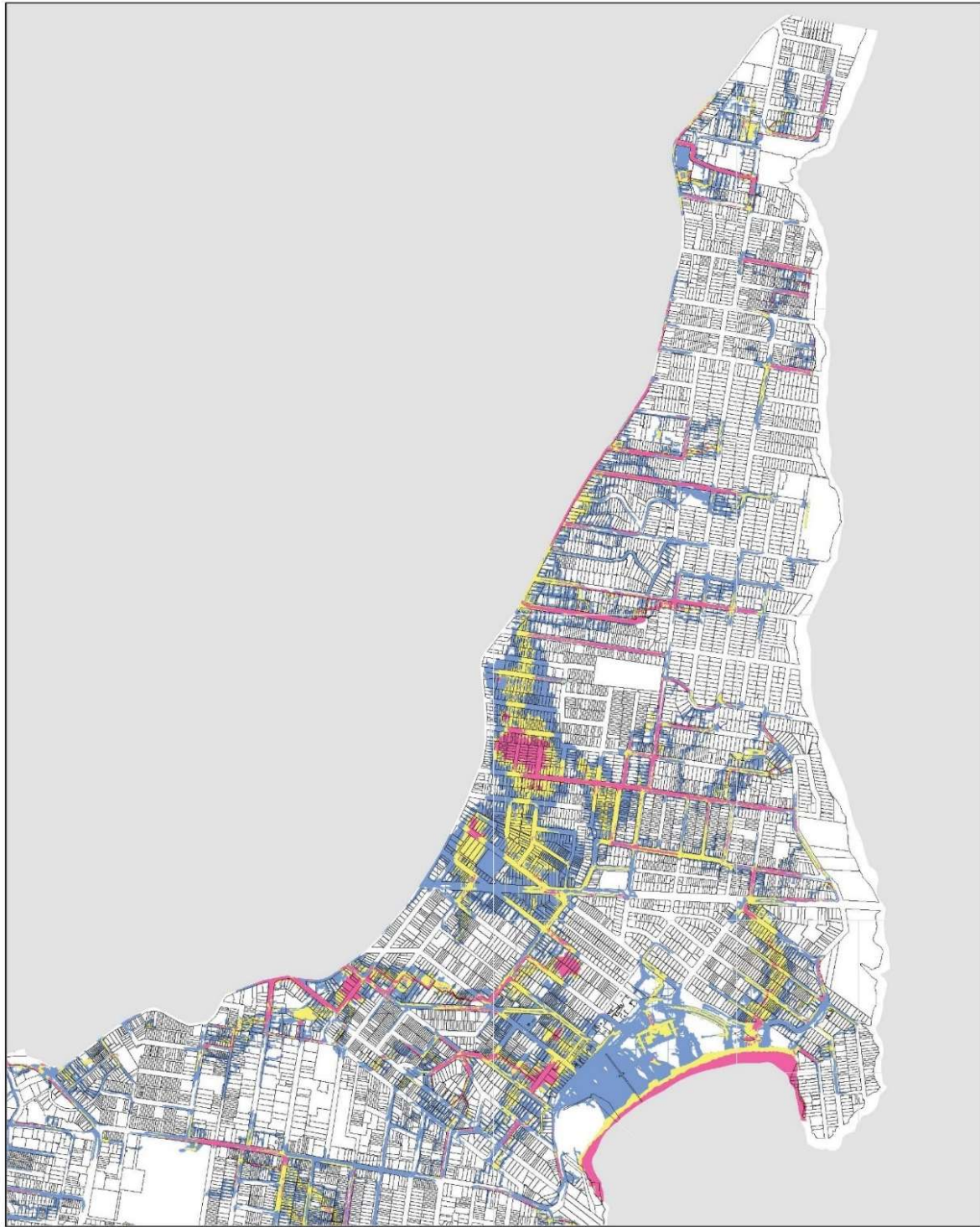
**Annexure B5-3
Flood Planning Area**



	<p>Flood Risk Precincts</p> <ul style="list-style-type: none">LowMediumHigh	<p>Cadastral</p> <ul style="list-style-type: none">Cadastral 20/02/2026	<p>Disclaimer: This map is presented by Waverley Council for the purpose of disseminating information for the benefit of the public. No statement is made about the accuracy or suitability of the information for use for any purpose (whether the purpose has been notified to Council or not). While every care is taken to ensure the accuracy of this data, neither the Waverley Council nor the NSW Spatial Services makes any representations or warranties about its accuracy, reliability, completeness or suitability for any particular purpose and disclaims all responsibility and all liability (including without limitation, liability in negligence) for all expenses, losses, damages (including indirect or consequential damage) and costs which you might incur as a result of the data being inaccurate or incomplete in any way and for any reason. Contact: gis@waverley.nsw.gov.au</p>	 <p>Projection: GDA 2020 MGA Zone 56</p>	 <p>0 250 metres</p>	<p>Scale: 1:12,770 @ A3</p>	<p>Author: eSolutions Date created: 20/02/2026</p>
---	--	--	---	---	---	-----------------------------	--

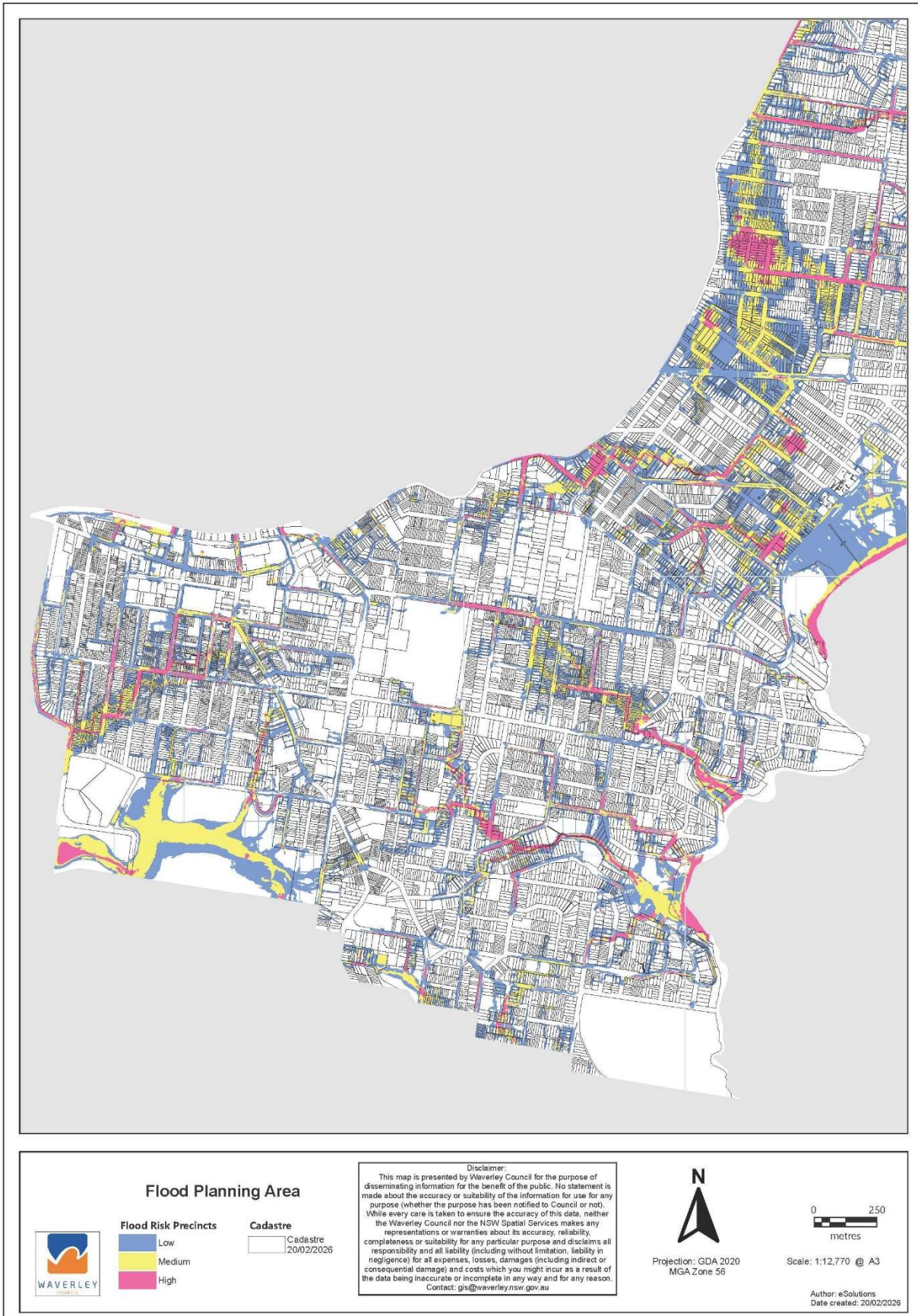

Note: The Flood Planning Area map is provided as a reference and is subject to administrative updates in line with updates to flood modelling in the Waverley LGA

Annexure B8-1**Charing Cross Conservation Area**

The following map highlights the study area, as well as an extract of the Charing Cross heritage conservation area (refer to Figure 37).

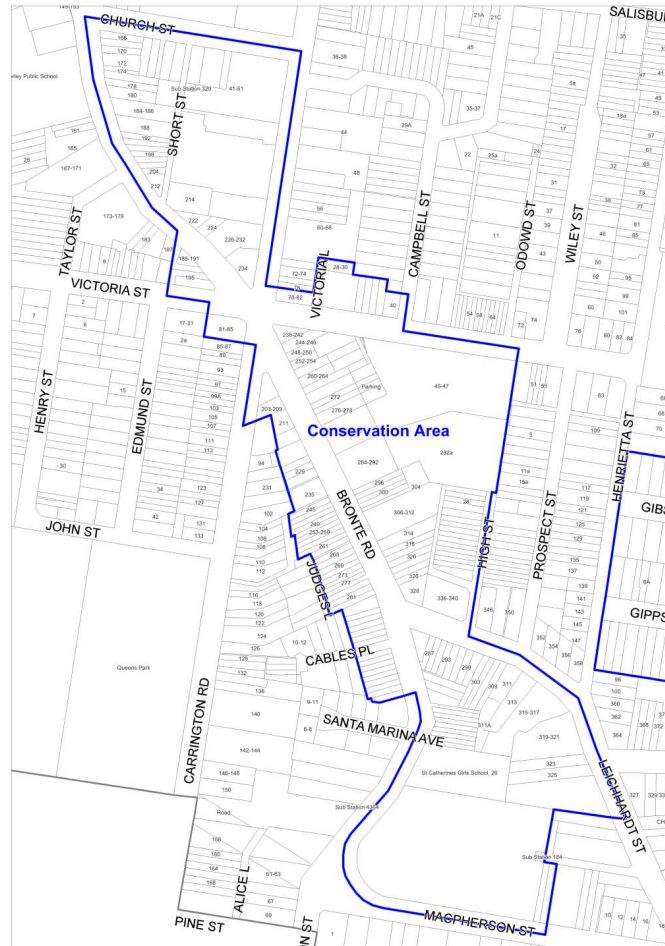

Figure 37 Charing Cross heritage conservation area

The following provides recommendations for future conservation opportunities as well as appropriate colour schemes for the identified properties or property groups. Furthermore, the Charing Cross Streetscape Study provides a physical description of every building or building group within the study area and general recommendations for the overall improvement of the streetscape. All of the buildings included in the study are located in the Charing Cross heritage conservation area.

Conservation of Original Fabric

A large amount of original fabric still exists in the street facades of the conservation area, particularly in the upper wall areas above the awnings. However, much of it has been compromised by later additions or is covered by unsympathetic paint schemes. It is recommended that each period of building be respected for its individual contribution to the development of the area and that future treatment will be consistent with the original character of the building.

Original shopfronts are becoming increasingly rare and remaining examples should be conserved. Partial or missing examples of original fabric can be restored or reconstructed to aid interpretation and appreciation of the streetscape, however, this must be done with care and be based on evidence, thorough research and inspection of the physical evidence on site by an experienced conservation architect.

Colour Schemes

Cleaning and repainting the facades of the buildings in the study area would be an improvement to the presentation of the street. Many individual buildings have unsympathetic colour schemes that are inconsistent with the style of the building and with the grouping in which they were built. It is desirable that the colour scheme of each building or group of buildings be informed by the period in which it was built and by physical investigation of the early paint layers on the exterior fabric. A conservation architect or heritage practitioner could carry out paint scrapes to determine the early colours. These colours could then be interpreted in a colour scheme that suits the current owners or tenants. Correct tonal relationships (the use of light and dark colours on various elements) are more important than exact replication of hues.

The accompanying inventory sheets for each building or group of buildings contain recommended colour schemes which are based on the period, style, and current treatment of the buildings. For example, in some cases where original face brickwork has been painted over, the colour scheme provides a recommendation to paint the brickwork brown to simulate face brick. These recommended colour schemes are speculative, relying on knowledge of original colour schemes of other buildings of similar periods, and are not based on physical intervention. It is preferable to undertake paint scrapes to determine the original colour scheme of each building, however, if this is not possible, the recommended colour schemes would result in a more historically relevant appearance of the streetscape.

Colour terms used in the inventory sheets relate to the Australian Standard 2700 - Colour Standards for General Purposes as follows:

Colour name	AS2700 colour name	AS2700 code
Biscuit	Raffia	X31
Bridge grey	Light grey	N35
Bronze green	Deep bronze green	G63
Brown (to simulate brickwork)	N/A – approve by sample	
Buff	Oatmeal	Y54
Copper beech	Dark brown	X65
Cream	Sandstone	Y53
Crimson	Maroon	R65
Deep Brunswick green	Bottle green	G11
Eau-de-Nil	Palm green	G44
Forest green	Holly	G12
French grey	Storm grey	N42
Grey green	Banksia	G53
Indian red	Deep indian red	R64
Manilla	Manilla	Y45
Mid-brown	Brown	X54
Mountain blue	Blue jay	T24
Off-white	Off-white	Y35

Colour name	AS2700 colour name	AS2700 code
Olive	Mist green	G54
Pale grey (to simulate render)	N/A – approve by sample	
Pink brown	Cinnamon	X45
Sea green	Lichen	G55
Vellum	Surf green	G43
Venetian red	Venetian red	R62
White	N/A	N/A

Recommended Finishes

All render and plaster should have a semi-gloss finish. All timber and metalwork should have a gloss finish.

Annexure B8-2

Queens Park Conservation Area

The Queens Park Conservation Area (QPCA) has been identified as an area that has unique physical qualities and an intrinsic residential character that should be preserved (refer to Figure 38). Any property within the QPCA must have regard for the Desired Future Character as outlined in Annexure B8-2 and adhere to the Objectives and Controls within Part B8.



Figure 38 Queens Park Conservation Area

Subdivision

Streets in the area are arranged in a grid pattern with most blocks containing internal rear service lanes. The subdivision pattern features three categories of lot size, reflecting the type of dwellings in the area. Small sized lots (typically 100m² to 250m²) dominate the north-eastern portion of the study area. These lots typically contain Victorian terraces and other attached dwelling styles (refer to Figure 39).

Queens Park Heritage Conservation Area



Figure 39 Example of Victoria terraces in the area

In the central and southern part of the area, lots tend to be larger (typically 200m² to 400m²) reflecting the semi-detached and detached villa dwelling typology (refer to Figure 40).



Figure 40 Example of semi-detached dwellings in the area

The largest lots (500m² to 800m²) are present on the western and southern edges of the area, fronting onto Queens Park Road and York Road. These lots contain bungalow style dwellings with a large front set back, and a small number of residential flat buildings (refer to Figure 41).

Views and Vistas

North-south street axes provide important view corridors to Queens Park. Formal tree plantings in these streets frame views to the open parkland in the distance. Properties in the upper eastern portion of the area enjoy distant views of parklands and the city to the west.



Figure 41 Example of the detached bungalow dwelling style in the area

Open Space

Queens Park and Centennial Park are expansive areas of open space bordering the character area to the south and west respectively. These parklands are significant landmarks and provide a contrast to the compact residential character of the area.

Landscaping

Vegetation is an important element to the character of this area. Formal plantings of mature fig trees are the most distinguishing characteristic of the inner residential streets and provide a uniting theme throughout the study area. The sense of enclosure created by the avenues of mature trees is in contrast to the openness of the parkland bordering the area to the south and west (refer to Figure 42).

Residential Character – Streetscapes

Three distinct types of streetscape character are found within the area. Streets which carry larger volumes of local through traffic (e.g. Birrell Street, Queens Park Road, York Road), inner residential streets (e.g. Manning Street, Alt Street, Ashton Street) and rear access lanes.

The streets with higher volumes of through traffic have a wider carriageway, relatively narrow verges and smaller scale and less dense street plantings. These features contribute to a wider, more open streetscape (refer to Figure 43).

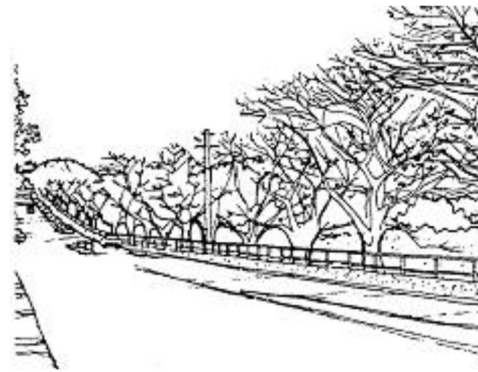

Figure 42 Open views, established street trees and rock outcrops are a unique character of Queens Park

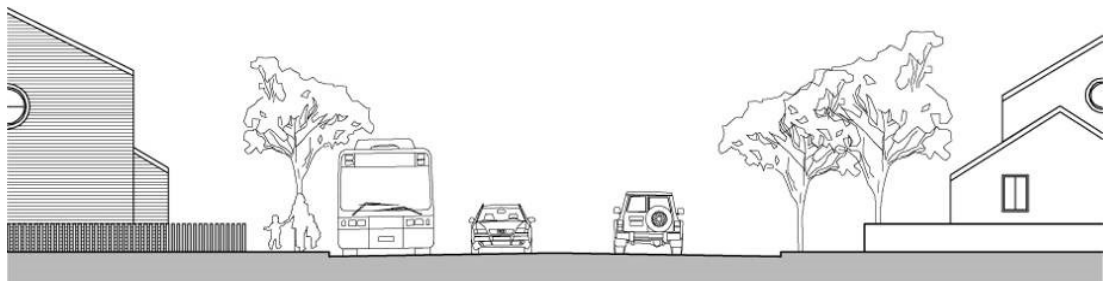

Figure 43 Typical section of a street with high volumes of through traffic

Inner residential streets are characterized by mature trees forming a canopy. These streets are foliage shaded, with a cooler microclimate, and wider verges (refer to Figure 44).

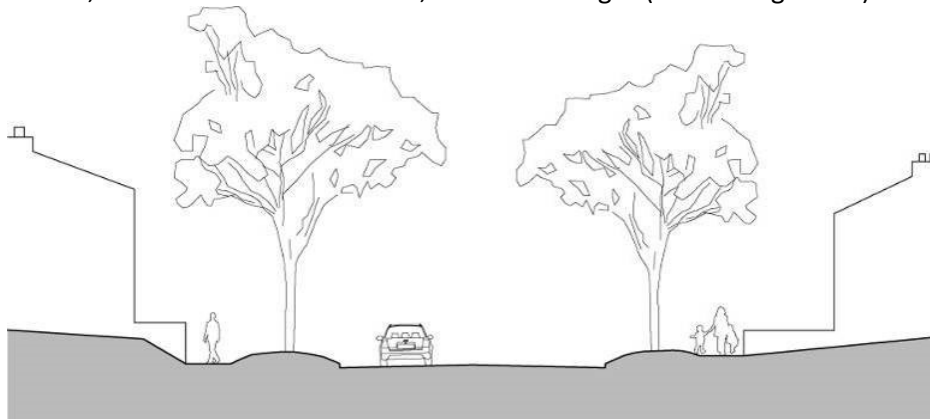

Figure 44 Typical section of an inner residential street

The narrow, corridor like rear access lanes are dominated by garage doors, high fences, walls, landscape screening, and a variety of building setbacks (refer to Figure 45). A variety of front fence styles and setback conditions typify the range of dwelling styles represented in the area. Shallow front setbacks with cast iron front fences are part of the original character of Victorian terraces. While most remain intact, some have been replaced with higher, rendered brick fences. Detached and semi-detached dwellings typically have deeper front setbacks, with low brick or timber picket front fences being the most common styles (refer to Figure 46).

Low, stepped brick fences are used on steeper sites and where no rear lane access is provided, garage doors and sloped landscaping face the street (refer to Figure 47).

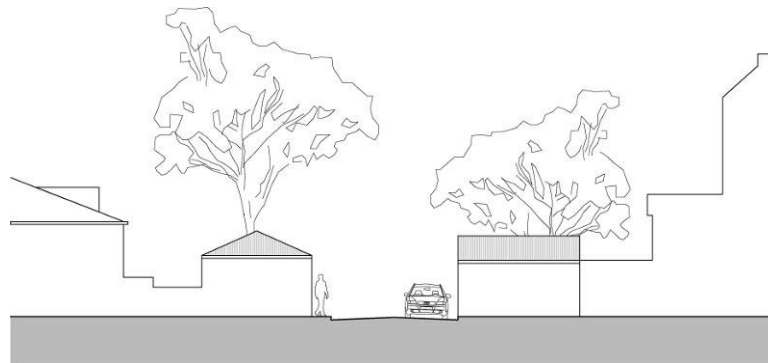

Figure 45 Typical section of a rear access lane.

Architectural Style

QPCA is one of the oldest precincts in the Municipality, containing many manmade and natural heritage items, including remnants of walls, stables, buildings, caves and trees. Any development must be sensitive to these items.

A variety of architectural styles reflect the various eras of development in the study area. These include the Victorian Terrace, sandstone Post Regency cottage, Victorian Gothic, Edwardian and Federation semidetached dwellings and larger Federation, Californian and Modern bungalows. Most dwellings are clustered in groups of similar style. Repetition of building elements such as shingled gables, chimneys, doors and windows, terraces, entrances, fences, etc. establishes a coherent streetscape character based on detail and rhythm.

Recent development has increased the vocabulary of the character of the area. New dwellings and alterations and additions range from minor dormer windows to contemporary architecture.



Figure 46 Example of low and transparent fences which correspond to the established existing character elements.



Figure 47 Stepped fences on steeper sites